

# Relativistic quantum mechanics

(Lecture notes - a.a. 2022/23)

Fiorenzo Bastianelli

## 1 Introduction

The Schrödinger equation is a wave equation for the quantum mechanics of non-relativistic particles. The attempts to generalize it to the relativistic case led historically to the discovery of many different wave equations (Klein-Gordon, Dirac, Proca-Maxwell, etc.). It soon became clear that all of these wave equations for relativistic particles had some interpretative problems: *i*) some did not admit a probabilistic interpretation, and *ii*) all of them included states with negative energy. These equations are often called “first quantized” equations, as they are obtained by quantizing the mechanics of a single relativistic particle.

To solve those problems, eventually one had to reinterpret them as equations for classical fields (just like Maxwell’s equations) that should be quantized anew (hence the name of “second quantization” given to the *quantum theory of fields*). All of the interpretative problems can be solved consistently within the framework of quantum field theory: the quantum fields are seen to describe an arbitrary number of indistinguishable particles (the quanta of the field, like the photons for the electromagnetic field). The relativistic equations mentioned above remain valid, but reinterpreted as equations satisfied by quantum field operators.

Why is that so? The main reason is that in relativity particles can be created and destroyed in physical processes. It would not be consistent to fix the number of particles, and require that number to be conserved. Indeed, let us recall that relativity assigns the energy  $E = mc^2$  to a particle of mass  $m$  at rest. In the limit  $c \rightarrow \infty$ , which formally describes the nonrelativistic limit, it would take an infinite amount of energy to create a particle. Non-relativistic quantum mechanics can be developed in a consistent way to conserve the number of particles. In relativistic quantum mechanics it is impossible to do so: certain processes which carry enough energy may allow the creation of new particles, as observed in nature. This explains the failure to have a probabilistic interpretation for the quantum mechanics of a single particle. The other problem, the presence of negative energy states, was eventually turned into a prediction: the existence of antiparticles!

Given that the methods of second quantization (alias quantum field theory or QFT) is the natural mathematical framework to study the above properties, why to review the historical development? There are many justifications to do so. One reason is that the historical development clarifies the physical ideas leading to more formal constructions, such as QFT. A second motivation is that one finds that many physical situations can be dealt with – often in a simpler way – in the context of first quantization, i.e. using relativistic quantum mechanics, without the need of turning to more elaborate methods. This happens for example if one considers those cases where pair creation is suppressed, so that the single-particle approximation is applicable. More generally, first-quantized methods, that nowadays go under the name of the *worldline formalism*, are often used as efficient tools to study the scattering of relativistic particles. Finally, it has some pedagogical value for studying *string theory*, a model for quantum

gravity where particles are generalized to strings. String theory has been mostly developed in first-quantization.

The different relativistic wave equations mentioned above correspond to the quantum mechanics of particles with different spin  $s$ . There is also a difference if the particle is massive ( $m \neq 0$ ) or massless ( $m = 0$ ) if the spin is  $s > 0$ . The simplest relativistic equation is the Klein-Gordon equation, that describes scalar particles, i.e. particles of spin  $s = 0$ . It takes into account the correct relativistic relation between energy and momentum, and thus it contains the essence of all relativistic wave equations (like negative energy solutions, that signal the need for antiparticles). The correct wave equation for a relativistic particle depends crucially on the value of the spin  $s$ , and the standard names are as follows:

- spin 0  $\rightarrow$  Klein-Gordon equation
  - spin  $\frac{1}{2}$   $\rightarrow$  Dirac equation
  - spin 1 ( $m \neq 0$ )  $\rightarrow$  Proca equation
  - spin 1 ( $m = 0$ )  $\rightarrow$  (free) Maxwell equations
  - spin  $\frac{3}{2}$   $\rightarrow$  Rarita-Schwinger equation
  - spin 2  $\rightarrow$  Fierz-Pauli equations (or linearized Einstein eq. for  $m = 0$ ).
- etc.

We have anticipated that relativistic particles are classified by their mass  $m$  and spin  $s$ , where the value of the spin indicates that there are only  $2s + 1$  independent physical components of the wave function, describing the possible polarizations of the spin vector along a chosen axis. That is true unless  $m = 0$ , in which case the wave function describes only two physical components, those with maximum and minimum helicity (helicity is the projection of the spin along the direction of motion). The reduction of the number of degrees of freedom is mathematically achieved by the emergence of gauge symmetries satisfied by the corresponding wave equations, as we shall see in the examples of spin 1 and 2.

The classification just described is due to Wigner, that in 1939 studied the *unitary irreducible representations of the Poincaré group*. The Poincaré group is by definition the group of symmetries of relativistic theories, symmetries that must be realized by unitary operators in the Hilbert space of the particle. Different particles have different realizations (i.e. representations) of the symmetry group, and Wigner's theorem describes the possible different unitary representations that are allowed by group theory. As anticipated, a physical way of understanding Wigner's classification is to recall that for a massive particle of spin  $s$ , one may always find a reference frame where the particle is at rest. Then, its spin is observed to have the  $2s + 1$  physical projections along the  $z$ -axis, as known from standard quantum mechanics. Thus, we understand that massive particles of spin  $s$  must have  $2s + 1$  physical polarizations. On the other hand, a rest frame does not exist if the particle is massless: the particle must travel with the speed of light in any frame. Choosing the direction of motion as the axis where to measure the spin, one finds that only two values of the helicity  $h = \pm s$  are possible. Other helicities are not needed, as they would never mix with the previous ones under Lorentz (and Poincaré) transformations (they could be considered as belonging to different particles, which may or may not exist in a given model. On the contrary, the discrete CPT symmetry requires both helicities  $\pm s$  to be present).

In these notes, after a brief review of the Schrödinger equation, we discuss the main properties of the Klein-Gordon and Dirac equations, treated as first quantized wave equations for particles of spin 0 and  $\frac{1}{2}$ , and then briefly comment on other relativistic free wave equations.

Our main conventions for special relativity are as follows:

$$x^\mu = (ct, x, y, z) = (x^0, x^1, x^2, x^3) \quad (\text{spacetime coordinates})$$

$$x'^\mu = \Lambda^\mu{}_\nu x^\nu \quad (\text{Lorentz transformations})$$

$$\eta_{\mu\nu} = \text{diag}(-1, 1, 1, 1) \quad (\text{Minkowski metric})$$

$$s^2 = \eta_{\mu\nu} x^\mu x^\nu = x^\mu x_\mu \quad (\text{invariant length})$$

$$\eta^{\mu\nu} = (\eta^{-1})^{\mu\nu} \quad (\text{inverse metric})$$

$$x_\mu = \eta_{\mu\nu} x^\nu, \quad x^\mu = \eta^{\mu\nu} x_\nu \quad (\text{lowering/raising indices})$$

$$O(3, 1) = \{\text{real } 4 \times 4 \text{ matrices } \Lambda \mid \Lambda^T \eta \Lambda = \eta\} \quad (\text{Lorentz group})$$

$$SO^+(3, 1) = \{\text{real } 4 \times 4 \text{ matrices } \Lambda \mid \Lambda^T \eta \Lambda = \eta, \det \Lambda = 1, \Lambda^0{}_0 \geq 1\} \quad (\text{proper orthochronous Lorentz gr.})$$

$$x'^\mu = \Lambda^\mu{}_\nu x^\nu + a^\mu \quad (\text{Poincaré transformations})$$

$$\partial_\mu = \frac{\partial}{\partial x^\mu} \quad (\text{spacetime derivative})$$

$$\partial'_\mu = \Lambda_\mu{}^\nu \partial_\nu, \quad \Lambda_\mu{}^\nu \equiv \eta_{\mu\alpha} \Lambda^\alpha{}_\beta \eta^{\beta\nu} = (\eta \Lambda \eta^{-1})_\mu{}^\nu = (\Lambda^{T,-1})_\mu{}^\nu \quad (\text{Lorentz transformation of derivatives})$$

$$F'^{\mu\nu} = \Lambda^\mu{}_\alpha \Lambda^\nu{}_\beta F^{\alpha\beta} \quad (\text{Lorentz transformation of rank 2 tensor})$$

## 2 Schrödinger equation

Crucial moments in the discovery of quantum mechanics are:

- (1900) the introduction of the Planck's constant  $h$  in describing the black body radiation,
- (1905) the use of  $h$  made by Einstein in explaining the photoelectric effect, with photons of energy  $E = h\nu$  interpreted as quanta of the electromagnetic waves,
- (1913) the introduction of Bohr's atomic model with quantized energy levels  $E_n \sim \frac{1}{n^2}$ .

At this point, it was still unclear which fundamental laws could organize the quantum phenomena emerging from the subatomic world. An important contribution came from de Broglie, who in 1923 suggested an extension of Einstein's idea by conjecturing a wave behaviour for particles of matter. He assigned a wavelength  $\lambda = \frac{h}{p}$  to material particles with moment  $p = |\vec{p}|$ . This assumption could explain Bohr's quantized energy levels: one could interpret them as the ones for which an integer number of electron wavelengths would fit in the electron periodic trajectory around the nucleus. de Broglie was inspired by relativity in making his proposal: a periodic wave function with frequency  $\nu = \frac{1}{T}$ , where  $T$  is the period (periodicity in time), and with wave number  $\vec{k}$ , where  $|\vec{k}| = \frac{1}{\lambda}$  with  $\lambda$  the wavelength (periodicity in space), has the mathematical form of a plane wave

$$\psi(\vec{x}, t) \sim e^{2\pi i(\vec{k} \cdot \vec{x} - \nu t)}. \quad (1)$$

Assuming the phase  $2\pi(\vec{k} \cdot \vec{x} - \nu t)$  to be Lorentz invariant, and knowing that the spacetime coordinates  $(ct, \vec{x}) = x^\mu$  form a four-vector, de Broglie deduced that also  $(\frac{\nu}{c}, \vec{k}) = k^\mu$  would form a four-vector, and thus be subject to the same Lorentz transformations of the four-vector  $(ct, \vec{x}) = x^\mu$  or four-momentum  $(\frac{E}{c}, \vec{p}) = p^\mu$ . Since in the case of photons  $E = h\nu$ , it was natural to extend the relation to the complete four-vectors  $(\frac{E}{c}, \vec{p})$  and  $(\frac{\nu}{c}, \vec{k})$  with the same proportionality constant  $h$ , i.e.  $p^\mu = hk^\mu$ , to obtain

$$E = h\nu, \quad \vec{p} = h\vec{k}. \quad (2)$$

The second relation implies that  $\lambda = \frac{h}{|\vec{p}|}$  and assigns a wavelength to a material particle with momentum  $\vec{p}$ . Hence, a plane wave associated to a free particle with fixed energy and momentum should take the mathematical form

$$\psi(\vec{x}, t) \sim e^{2\pi i(\vec{k}\cdot\vec{x}-\nu t)} = e^{\frac{2\pi i}{h}(\vec{p}\cdot\vec{x}-Et)} = e^{\frac{i}{\hbar}(\vec{p}\cdot\vec{x}-Et)}. \quad (3)$$

At this point Schrödinger asked: what kind of equation does this function satisfy? He began directly with the relativistic case, but as he could not reproduce experimental results for the hydrogen atom, he used the non-relativistic limit that seemed to work better (today we know that relativistic corrections are compensated by effects due to the spin of the electron, which were not taken into account). For a free non-relativistic particle  $E = \frac{\vec{p}^2}{2m}$ , the wave function (3) postulated by de Broglie satisfies

$$i\hbar\frac{\partial}{\partial t}\psi(\vec{x}, t) = E\psi(\vec{x}, t) = \frac{\vec{p}^2}{2m}\psi(\vec{x}, t) = -\frac{\hbar^2}{2m}\nabla^2\psi(\vec{x}, t). \quad (4)$$

Thus, it solves the differential equation

$$\boxed{i\hbar\frac{\partial}{\partial t}\psi(\vec{x}, t) = -\frac{\hbar^2}{2m}\nabla^2\psi(\vec{x}, t)} \quad (5)$$

which is the free Schrödinger equation. Turning things around, Schrödinger's equation produces plane wave solutions for the quantum mechanics of a nonrelativistic particle of mass  $m$ .

This construction suggests a prescription for obtaining a wave equation from a classical model of a particle:

- consider the classical relation between energy and momentum, e.g.  $E = \frac{\vec{p}^2}{2m}$
- replace  $E \rightarrow i\hbar\frac{\partial}{\partial t}$  and  $\vec{p} \rightarrow -i\hbar\vec{\nabla}$
- interpret these differential operators as acting on a wave function  $\psi$

$$i\hbar\frac{\partial}{\partial t}\psi(\vec{x}, t) = -\frac{\hbar^2}{2m}\nabla^2\psi(\vec{x}, t).$$

These are the quantization prescriptions that produce the Schrödinger equation from the classical theory of a point particle. Schrödinger extended those considerations to a charged particle in the Coulomb field of a nucleus to explore the consequences of quantum mechanics, achieving a considerable success in reproducing the results of Bohr's atomic model.

Although originally inferred from the non-relativistic limit of a point particle, when written in the form

$$i\hbar\frac{\partial}{\partial t}|\psi\rangle = \hat{H}|\psi\rangle \quad (6)$$

with  $\hat{H}$  the Hamiltonian operator, the Schrödinger equation acquires a universal validity for the quantum mechanics of any physical system.

### Conservation of probability

When a non-relativistic particle is described by a normalizable wave function  $\psi(\vec{x}, t)$  (the plane wave in the infinite space considered above is not normalizable, and thus one should

consider wave packets), one can interpret the quantity  $\rho(\vec{x}, t) = |\psi(\vec{x}, t)|^2$  as the density of probability to find the particle in point  $\vec{x}$  at time  $t$ . In particular, one can prove that  $\rho$  satisfies a continuity equation

$$\frac{\partial \rho}{\partial t} + \vec{\nabla} \cdot \vec{J} = 0 \quad (7)$$

with a suitable current  $\vec{J}$ , namely  $\vec{J} = \frac{\hbar}{2im}(\psi^* \vec{\nabla} \psi - \psi \vec{\nabla} \psi^*)$ . This is equivalent to the conservation of probability: at each moment of time the particle is somewhere in space. It is consistent to assume that a non-relativistic particle cannot be created or destroyed. This is physically understandable by looking at the non-relativistic limit of a relativistic particle, obtained by sending  $c \rightarrow \infty$ : from the energy formula one finds

$$E = \sqrt{\vec{p}^2 c^2 + m^2 c^4} = mc^2 \sqrt{1 + \frac{\vec{p}^2}{m^2 c^2}} \implies mc^2 + \frac{\vec{p}^2}{2m} + \dots \quad (8)$$

so that for  $c \rightarrow \infty$  it would take an infinite amount of energy to create a particle of mass  $m$ .

### 3 Spin 0: Klein-Gordon equation

As we have seen the Schrödinger equation can be obtained by the quantization of a nonrelativistic particle. Similarly, the Klein-Gordon equation can similarly be obtained from the quantization of a relativistic particle (first quantization). However, we shall see that this equation does not admit a probabilistic interpretation. The full consistency with quantum mechanics will eventually be recovered by treating the Klein-Gordon wave function as a classical field, and then quantizing it anew as a system with an infinite number of degrees of freedom (just like the electromagnetic field, that historically was the first example to be treated as a quantum field). Often one refers to the quantization of the field as “second quantization”. In second quantization the Klein-Gordon field describes an arbitrary number of identical particles of zero spin together with their antiparticles. Nevertheless, remaining within the scope of first quantization, the Klein-Gordon equation gives much information on the quantum mechanics of relativistic particles of spin 0.

#### Derivation of the Klein-Gordon equation

How to get a relativistic wave equation? A simple idea is to proceed as described previously, by using the correct relativistic relation between energy and momentum. We know that a free relativistic particle of mass  $m$  has a four-momentum  $p^\mu = (p^0, p^1, p^2, p^3) = (\frac{E}{c}, \vec{p})$  that satisfies the mass-shell condition

$$p_\mu p^\mu = -m^2 c^2 \implies -\frac{E^2}{c^2} + \vec{p}^2 = -m^2 c^2 \implies E^2 = \vec{p}^2 c^2 + m^2 c^4. \quad (9)$$

Thus, one could try to use  $E = \sqrt{\vec{p}^2 c^2 + m^2 c^4}$ , but the equation emerging from the substitution  $E \rightarrow i\hbar \frac{\partial}{\partial t}$  and  $\vec{p} \rightarrow -i\hbar \vec{\nabla}$  looks very complicated

$$i\hbar \frac{\partial}{\partial t} \phi(\vec{x}, t) = \sqrt{-\hbar^2 c^2 \nabla^2 + m^2 c^4} \phi(\vec{x}, t). \quad (10)$$

It contains the square root of a differential operator, whose meaning is rather obscure. It is difficult to interpret it. It seems to describe non-local phenomena, in which points far

apart influence strongly each other. This approach was soon abandoned. Then, Klein and Gordon proposed a simpler equation, considering the quadratic relationship between energy and momentum. Starting from  $E^2 = \vec{p}^2 c^2 + m^2 c^4$ , and using  $E \rightarrow i\hbar \frac{\partial}{\partial t}$  e  $\vec{p} \rightarrow -i\hbar \vec{\nabla}$ , they obtained the Klein-Gordon equation

$$\left( -\frac{1}{c^2} \frac{\partial^2}{\partial t^2} + \nabla^2 - \frac{m^2 c^2}{\hbar^2} \right) \phi(\vec{x}, t) = 0 . \quad (11)$$

written in relativistic notations as ( $\partial_\mu = \frac{\partial}{\partial x^\mu}$ )

$$(\partial_\mu \partial^\mu - \mu^2) \phi(x) = 0 , \quad \mu \equiv \frac{mc}{\hbar} \quad (12)$$

and also as

$$(\square - \mu^2) \phi(x) = 0 \quad (13)$$

where  $\square \equiv \eta^{\mu\nu} \partial_\mu \partial_\nu = \partial_\mu \partial^\mu = -(\partial_0)^2 + \nabla^2 = -\frac{1}{c^2} \frac{\partial^2}{\partial t^2} + \nabla^2$  is the d'Alembertian.

Equivalently, in a more compact and covariant way one may start for the classical mass-shell relation  $p_\mu p^\mu + m^2 c^2 = 0$  and quantize it by the replacement  $p_\mu \rightarrow -i\hbar \partial_\mu$  to find eq. (12).

According to Dirac, Schrödinger considered it before deducing its famous equation, but dissatisfied with the results that seemed to produce for the hydrogen atom, he settled with its non-relativistic limit. When later he decided to reconsider it, he found that Klein and Gordon had already published their results.

From now on we shall use natural units with  $\hbar = c = 1$ , so to identify  $\mu = m$  (unless specified differently).

### Plane wave solution

The Klein-Gordon equation has been constructed by requiring that it should have plane waves solutions with the correct dispersion relation between energy and momentum

$$(\square - m^2) \phi(x) = 0 . \quad (14)$$

One can easily rederive the plane wave solutions by a direct analysis. Let us look for solutions with a plane wave ansatz of the form

$$\phi_p(x) \sim e^{ip_\mu x^\mu} \quad (p_\mu \text{ arbitrary}) \quad (15)$$

which inserted in (14) produces

$$-(p^\mu p_\mu + m^2) e^{ip_\nu x^\nu} = 0 . \quad (16)$$

Thus, the plane wave is a solution if  $p_\mu$  satisfies the mass-shell condition

$$p^\mu p_\mu + m^2 = 0 \quad (17)$$

that is solved by

$$(p^0)^2 = \vec{p}^2 + m^2 \quad \implies \quad p^0 = \pm \underbrace{\sqrt{\vec{p}^2 + m^2}}_{E_p > 0} = \pm E_p . \quad (18)$$

Apart from the desired solutions with positive energy, one sees immediately that there are solutions with negative energy, whose immediate interpretation is not obvious. They cannot be neglected, as interactions could lead to transitions to the negative energy levels. The model does not have an energy limited from below, and does not seem stable (eventually, solutions with negative energy  $p^0 = -E_p$  will be reinterpreted in the quantum theory of fields as describing antiparticles with positive energy, as we shall see when discussing the propagator).

All plane wave solutions are indexed by the value of the spatial momentum  $\vec{p} \in R^3$ , and by the sign of  $p^0 = \pm E_p$ . The positive energy solutions are given by

$$\phi_{\vec{p}}^+(x) = e^{-iE_p t + i\vec{p}\cdot\vec{x}} \quad (19)$$

and the negative energy solutions are given by

$$\phi_{\vec{p}}^-(x) = e^{iE_p t - i\vec{p}\cdot\vec{x}}. \quad (20)$$

where, by convention, it is useful to change the value of  $\vec{p}$  (then they are related by complex conjugation,  $\phi_{\vec{p}}^{+*} = \phi_{\vec{p}}^-$ ).

A general solution can be written as a linear combination of these plane waves

$$\phi(x) = \int \frac{d^3p}{(2\pi)^3} \frac{1}{2E_p} \left( a(\vec{p}) e^{-iE_p t + i\vec{p}\cdot\vec{x}} + b^*(\vec{p}) e^{iE_p t - i\vec{p}\cdot\vec{x}} \right) \quad (21)$$

and

$$\phi^*(x) = \int \frac{d^3p}{(2\pi)^3} \frac{1}{2E_p} \left( b(\vec{p}) e^{-iE_p t + i\vec{p}\cdot\vec{x}} + a^*(\vec{p}) e^{iE_p t - i\vec{p}\cdot\vec{x}} \right) \quad (22)$$

where the factor  $\frac{1}{2E_p}$  is conventional. For real fields ( $\phi^* = \phi$ ) the different Fourier coefficients coincide,  $a(\vec{p}) = b(\vec{p})$ .

### Continuity equation

From the KG equation one can derive a continuity equation, which however cannot be interpreted as due to the conservation of probability. Let us look at the details.

One way of getting the continuity equation is to take the KG equation multiplied by the complex conjugate field  $\phi^*$ , and subtract the complex conjugate equation multiplied by  $\phi$ . One finds

$$0 = \phi^*(\square - m^2)\phi - \phi(\square - m^2)\phi^* = \partial_\mu(\phi^*\partial^\mu\phi - \phi\partial^\mu\phi^*). \quad (23)$$

Thus the current  $J^\mu$  defined by

$$J^\mu = \frac{1}{2im}(\phi^*\partial^\mu\phi - \phi\partial^\mu\phi^*) \quad (24)$$

satisfies the continuity equation  $\partial_\mu J^\mu = 0$  (the normalization is chosen to make it real and to match  $\vec{J}$  with the probability current associated to the Schrödinger equation). The temporal component

$$J^0 = \frac{1}{2im}(\phi^*\partial^0\phi - \phi\partial^0\phi^*) = \frac{i}{2m}(\phi^*\partial_0\phi - \phi\partial_0\phi^*) \quad (25)$$

although real, is not positive. This is seen from the fact that both the field  $\phi$  and its time derivative  $\partial_0\phi$  can be arbitrarily fixed as initial conditions (the KG equation is a second-order

differential equation in time).  $J^0$  is fixed by these initial data and can be made either positive or negative. One can explicitly verify this statement by evaluating  $J^0$  on plane waves

$$J^0(\phi_{\vec{p}}^{\pm}) = \pm \frac{E_p}{m} \quad (26)$$

to see that it can be either positive or negative.

We conclude that the Klein-Gordon equation does not admit a probabilistic interpretation. This fact stimulated Dirac to look for a different relativistic wave equation that could admit a probabilistic interpretation. He succeeded, but eventually it became clear that one had to reinterpret all wave equations of relativistic quantum mechanics as classical systems that must be quantized again, to find them describing identical particles of mass  $m$  (the quanta of the field) in a way similar to the interpretation of electromagnetic waves suggested by Einstein in explaining the photoelectric effect. This interpretation indeed was considered in 1935 by Yukawa, who used the Klein-Gordon equation to propose a theory of nuclear interactions with short-range forces.

Thus, before describing the Dirac equation, we continue to treat the Klein-Gordon field as a classical field, keeping in mind its particle interpretation.

### Yukawa potential

Let us consider the KG equation in the presence of a static pointlike source

$$(\square - m^2)\phi(x) = g\delta^3(\vec{x}) \quad (27)$$

where the point source is located at the origin of the cartesian axes and the constant  $g$  measures the value of the charge (the intensity with which the particle is coupled to the KG field). Since the source is static, one may look for a time independent solution, and the equation simplifies to

$$(\vec{\nabla}^2 - m^2)\phi(\vec{x}) = g\delta^3(\vec{x}) . \quad (28)$$

It can be solved by Fourier transform. The result is the so-called Yukawa potential

$$\phi(\vec{x}) = -\frac{g}{4\pi} \frac{e^{-mr}}{r} . \quad (29)$$

To derive it, we use the Fourier transform

$$\phi(\vec{x}) = \int \frac{d^3k}{(2\pi)^3} e^{i\vec{k}\cdot\vec{x}} \tilde{\phi}(\vec{k}) . \quad (30)$$

Considering that the Fourier transform of the Dirac delta function (a “generalized function” or distribution) is given by

$$\delta^3(\vec{x}) = \int \frac{d^3k}{(2\pi)^3} e^{i\vec{k}\cdot\vec{x}} , \quad (31)$$

one finds

$$\tilde{\phi}(\vec{k}) = -\frac{g}{k^2 + m^2} \quad (32)$$

where  $k$  is the length of the vector  $\vec{k}$ . A direct calculation in spherical coordinates, using Cauchy’s residue theorem, gives

$$\phi(\vec{x}) = -g \int \frac{d^3k}{(2\pi)^3} \frac{e^{i\vec{k}\cdot\vec{x}}}{k^2 + m^2} = -\frac{g}{4\pi} \frac{e^{-mr}}{r} \quad (33)$$



where  $r = \sqrt{\vec{x}^2}$ . It can be shown that it gives rise to an attractive potential for charges of the same sign. It has a range  $\lambda \sim \frac{1}{m}$  corresponding to the Compton wavelength of a particle of mass  $m$ . Thus, it is used to model short-range forces, like the nuclear forces.

One can verify that (33) satisfies (28): use the laplacian written in spherical coordinates ( $\nabla^2 = \frac{1}{r^2}\partial_r r^2 \partial_r +$  derivatives on angles) to see that outside of the singularity at  $r = 0$  the solution (33) satisfies (28). On the other hand, the singular behavior at  $r = 0$  is related to the intensity of the point charge, just like in the Coulomb case, with the correct normalization obtained by comparison.

Details of the direct calculation: using spherical coordinates one evaluates

$$\begin{aligned}
\phi(\vec{x}) &= -g \int \frac{d^3k}{(2\pi)^3} \frac{e^{i\vec{k}\cdot\vec{x}}}{k^2 + m^2} \\
&= -\frac{g}{(2\pi)^3} \int_0^\infty k^2 dk \int_0^\pi \sin\theta d\theta \underbrace{\int_0^{2\pi} d\phi}_{2\pi} \frac{e^{ikr \cos\theta}}{k^2 + m^2} \\
&= -\frac{g}{(2\pi)^2} \int_0^\infty \frac{k^2 dk}{k^2 + m^2} \underbrace{\int_{-1}^1 dy e^{-ikry}}_{\frac{2 \sin(kr)}{kr}} \quad (y = -\cos\theta) \\
&= -\frac{g}{(2\pi)^2 r} \int_{-\infty}^\infty dk \frac{k}{k^2 + m^2} \sin(kr) \quad (\text{even function}) \\
&= -\frac{g}{(2\pi)^2 r} \int_{-\infty}^\infty dk \frac{k}{k^2 + m^2} \frac{e^{ikr}}{i} \quad (\text{odd function does not contribute}) \\
&= -\frac{g}{(2\pi)^2 r} 2\pi i \operatorname{Res} \left[ \frac{k e^{ikr}}{i(k+im)(k-im)} \right]_{k=im} = -\frac{g}{4\pi} \frac{e^{-mr}}{r} \quad (34)
\end{aligned}$$

where we have: used a change of variables ( $y = -\cos\theta$ ), extended the integration limit in  $k$  ( $\int_{-\infty}^\infty$ ) for the integral of an even function, added an odd function that does not change the value of the integral, interpreted the integral as performed on the real axis of the complex plane, added a null contribution to have a closed circuit in the upper half-plane, and used the Cauchy' residue theorem to evaluate the integral.

A graphical way that describes the interaction between two charges  $g_1$  and  $g_2$  mediated by the KG field (giving rise to the Yukawa potential) is given by the following ‘‘Feynman diagram’’

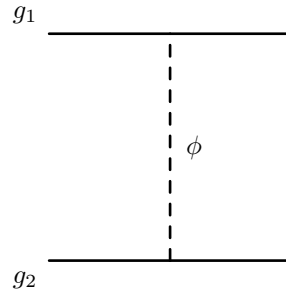

interpreted as an exchange of a virtual KG quantum between the worldlines of two scalar particles of charge  $g_1$  and  $g_2$ . It can be shown that this diagram produces the following interaction potential between the particles

$$V(r) = -\frac{g_1 g_2}{4\pi} \frac{e^{-mr}}{r}, \quad (35)$$

which is attractive for charges of the same sign. It is a potential for short ranges forces, with a characteristic radius  $R \sim \frac{1}{m}$ . In 1935 Yukawa introduced a similar KG scalar particle, called meson, to describe the nuclear forces. Estimating a radius  $R \sim 1$  fm, i.e. about the radius of the proton, one finds a mass  $m \sim 197$  MeV. The meson  $\pi^0$  (the pion, later discovered by studying cosmic ray interactions) has a mass of this order of magnitude,  $m_{\pi^0} \sim 135$  MeV.

### Green functions and the propagator

The Green functions of the KG equation are relevant for a quantum interpretation of the KG field (we now refrain from calling it KG wave function). A particular Green function is associated with the so-called propagator, which is interpreted as propagating a quantum of the field from a spacetime point to another. A Green function  $G(x)$  is defined as the solution of the KG equation in the presence of a pointlike and instantaneous source of unit charge, which for simplicity is located at the origin of the coordinate system. Mathematically, it is defined to satisfy the equation

$$(-\square + m^2)G(x) = \delta^4(x). \quad (36)$$

Knowing the Green function  $G(x)$ , one can represent a solution of the non-homogeneous KG equation

$$(-\square + m^2)\phi(x) = J(x) \quad (37)$$

where  $J(x)$  is an arbitrary function (a source) by

$$\phi(x) = \phi_0(x) + \int d^4y G(x-y)J(y). \quad (38)$$

with  $\phi_0(x)$  a solution of the associated homogeneous equation. This statement is verified inserting (38) in (37), and using the property (36).

In general, the Green function is not unique for hyperbolic differential equations, but it depends on the boundary conditions (chosen at infinity). In the quantum interpretation, the causal conditions devised by Feynman and Stueckelberg are used. They require to propagate forward in time the positive frequencies generated by the source  $J(x)$ , and back in time the remaining negative frequencies. In Fourier transform the solution is written as ( $d^4p \equiv dp^0 d^3p$ )

$$G(x) = \int \frac{d^4p}{(2\pi)^4} e^{ip_\mu x^\mu} \tilde{G}(p) = \int \frac{d^4p}{(2\pi)^4} \frac{e^{ip_\mu x^\mu}}{p^2 + m^2 - i\epsilon} \quad (39)$$

where  $\epsilon \rightarrow 0^+$  is a positive infinitesimal parameter that implements the boundary conditions stated above (the Feynman-Stueckelberg causal prescriptions). In a particle interpretation the Green function describes the propagation of “real particles” as well as the effects of “virtual particles”, all identified with the quanta of the scalar field. These particles can propagate at macroscopic distances only if the relation  $p^2 = -m^2$  holds (the pole that appears in the integrand compensates the effects of destructive interference due to the Fourier integral on the plane waves): they are called “real particles”. The quantum effects arising instead from the waves with  $p^2 \neq -m^2$  are considered as due to the “virtual particles” that are not visible at large distances (they do not propagate at macroscopic distances, and one interprets them as “hidden” by the uncertainty principle).

The prescription  $i\epsilon$  is designed to move appropriately the poles of the integrand, and corresponds to a very precise choice of the boundary conditions on the Green function: it corresponds to propagate forward in time the plane waves with positive energy ( $p^0 = E_p$ ) and backward in

time the fluctuations with negative energy ( $p^0 = -E_p$ ). This prescription is sometimes called causal, as it does not allow propagation in the future of negative energy states. The states with negative energy are sent back in time, and are interpreted as antiparticles with positive energy that propagate forward in time. We explicitly see how this interpretation emerges from the calculation of the integral in  $p^0$  of the Green function  $G(x - y)$  and related propagator defined by  $\Delta(x - y) = -iG(x - y)$ . The calculation also shows how the free field can be interpreted as a collection of harmonic oscillators. One obtains

$$\begin{aligned}
\Delta(x - y) &= -iG(x - y) = \int \frac{d^4p}{(2\pi)^4} \frac{-i}{p^2 + m^2 - i\epsilon} e^{ip \cdot (x - y)} \\
&= \int \frac{d^3p}{(2\pi)^3} e^{i\vec{p} \cdot (\vec{x} - \vec{y})} \int \frac{dp^0}{2\pi} e^{-ip^0(x^0 - y^0)} \frac{i}{(p^0 - E_p + i\epsilon')(p^0 + E_p - i\epsilon')} \\
&= \int \frac{d^3p}{(2\pi)^3} e^{i\vec{p} \cdot (\vec{x} - \vec{y})} \left[ \theta(x^0 - y^0) \frac{e^{-iE_p(x^0 - y^0)}}{2E_p} + \theta(y^0 - x^0) \frac{e^{-iE_p(y^0 - x^0)}}{2E_p} \right] \\
&= \int \frac{d^3p}{(2\pi)^3} e^{i\vec{p} \cdot (\vec{x} - \vec{y})} \frac{e^{-iE_p|x^0 - y^0|}}{2E_p} \tag{40}
\end{aligned}$$

where  $E_p = \sqrt{\vec{p}^2 + m^2}$  and  $\epsilon \sim \epsilon' \rightarrow 0^+$ . The integrals are evaluated by a contour integration on the complex plane  $p^0$ , choosing to close the contour with a semicircle of infinite radius that gives a null contribution, and evaluating the integral with Cauchy's residue theorem.

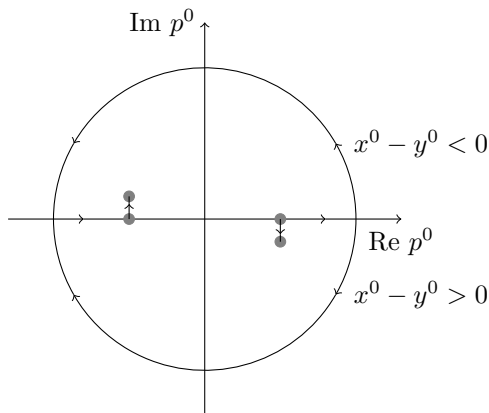

Figure 1: Contour integration around the poles with the Feynman  $i\epsilon$  prescription.

Recalling the form of the harmonic oscillator propagator ( $\sim \frac{e^{-i\omega|t-t'|}}{2\omega}$ ), that is going to be reviewed when studying the path integral quantization, one can see how the field can be interpreted as an infinite collection of harmonic oscillators parameterized by the frequency  $E_p$ .

Other prescriptions to displace the poles lead to different Green functions satisfying (36), which we now rewrite as

$$(-\square_x + m^2)G(x - y) = \delta^4(x - y) \tag{41}$$

with  $y^\mu$  the spacetime point that supports the external source. The retarded Green function  $G_R(x - y)$  is defined to propagate all frequencies excited by the source at the space-time point  $y^\mu$  forward in time, so that the retarded Green function vanishes for times  $x^0 < y^0$ . It is fixed

by displacing all the poles below the real  $p^0$  axis. The advanced Green function  $G_A(x - y)$  is defined to propagate all frequencies backward in time, so that it vanishes for  $x^0 > y^0$ . It is obtained by displacing the poles above the real  $p^0$  axis.

In the massless case ( $m = 0$ ), and setting again  $y^\mu = 0$  for simplicity, one computes the integrals and obtains

$$G_R(x) = \frac{1}{4\pi r} \delta(t - r), \quad G_A(x) = \frac{1}{4\pi r} \delta(t + r), \quad (42)$$

where  $t = x^0$  and  $r = \sqrt{\vec{x}^2}$ , as known from electromagnetism. They can be written in a form that is manifestly invariant under  $SO^+(3, 1)$

$$G_R(x) = \frac{\theta(x^0)}{2\pi} \delta(x^2), \quad G_A(x) = \frac{\theta(-x^0)}{2\pi} \delta(x^2). \quad (43)$$

*Exercise:* Derive the retarded and advanced Green functions in eqs. (43) by performing the momentum integrations.

*Exercise:* Rederive the Yukawa potential by using the propagator and eq. (38) with  $\phi_0 = 0$ .

### Action

The Klein-Gordon equation for a complex scalar field  $\phi(x)$  is conveniently obtained from an action principle

$$S[\phi, \phi^*] = \int d^4x \mathcal{L}, \quad \mathcal{L} = \left( -\partial^\mu \phi^* \partial_\mu \phi - m^2 \phi^* \phi \right). \quad (44)$$

Varying independently  $\phi$  and  $\phi^*$ , and imposing the least action principle

$$\delta S[\phi, \phi^*] = \int d^4x \left( \frac{\delta S[\phi, \phi^*]}{\delta \phi(x)} \delta \phi(x) + \frac{\delta S[\phi, \phi^*]}{\delta \phi^*(x)} \delta \phi^*(x) \right) = 0, \quad (45)$$

where suitable boundary conditions are imposed to eliminate the contributions from spacelike and timelike boundaries, one finds the equations of motion

$$\frac{\delta S[\phi, \phi^*]}{\delta \phi^*(x)} = (\square - m^2) \phi(x) = 0, \quad \frac{\delta S[\phi, \phi^*]}{\delta \phi(x)} = (\square - m^2) \phi^*(x) = 0. \quad (46)$$

For a real scalar  $\phi = \phi^*$ , the action is normalized conventionally as

$$S[\phi] = \int d^4x \left( -\frac{1}{2} \partial^\mu \phi \partial_\mu \phi - \frac{m^2}{2} \phi^2 \right) \quad (47)$$

from which one derives

$$\frac{\delta S[\phi]}{\delta \phi(x)} = (\square - m^2) \phi(x) = 0. \quad (48)$$

The complex scalar field can be seen as the combination of two real fields with the same mass. Setting

$$\phi = \frac{1}{\sqrt{2}} (\varphi_1 + i\varphi_2), \quad \phi^* = \frac{1}{\sqrt{2}} (\varphi_1 - i\varphi_2) \quad (49)$$

where  $\varphi_1$  and  $\varphi_2$  are the real and imaginary part, one recognizes that the lagrangian (44) becomes

$$\begin{aligned}\mathcal{L} &= -\partial^\mu \phi^* \partial_\mu \phi - m^2 \phi^* \phi \\ &= -\frac{1}{2} \partial^\mu \varphi_1 \partial_\mu \varphi_1 - \frac{1}{2} \partial^\mu \varphi_2 \partial_\mu \varphi_2 - \frac{m^2}{2} (\varphi_1^2 + \varphi_2^2).\end{aligned}\quad (50)$$

## Symmetries

The action allows to relate symmetries (invariances) to conservation laws. This relations is captured by the Noether's theorem. The free Klein-Gordon complex field has (rigid) symmetries generated by the Poincaré group (space-time symmetries) and (rigid) symmetries due to phase transformations described by the group  $U(1)$  (internal symmetries). The adjective “rigid” (or equivalently “global”) is meant to underlie that these are not gauge symmetries.

The  $U(1)$  symmetry is given by

$$\begin{aligned}\phi(x) &\longrightarrow \phi'(x) = e^{i\alpha} \phi(x) \\ \phi^*(x) &\longrightarrow \phi^{*'}(x) = e^{-i\alpha} \phi^*(x)\end{aligned}\quad (51)$$

and it is easy to see that the action (44) is invariant. It is equivalent to the  $O(2)$  symmetry that is manifest in the real basis used in eq. (50). Infinitesimal transformations take the form

$$\begin{aligned}\delta_\alpha \phi(x) &= \phi'(x) - \phi(x) = i\alpha \phi(x) \\ \delta_\alpha \phi^*(x) &= \phi^{*'}(x) - \phi^*(x) = -i\alpha \phi^*(x)\end{aligned}\quad (52)$$

and one can again verify that  $\delta_\alpha S[\phi, \phi^*] = 0$ . Extending the rigid parameter  $\alpha$  to an arbitrary function  $\alpha(x)$ , i.e. substituting  $\alpha \rightarrow \alpha(x)$  in eq. (52), does not give in general a symmetry but produces a variation of the form

$$\delta_{\alpha(x)} S[\phi, \phi^*] = \int d^4x \partial_\mu \alpha \underbrace{\left( i\phi^* \partial^\mu \phi - i(\partial^\mu \phi^*) \phi \right)}_{J^\mu}.\quad (53)$$

This variation allows us to verify again the  $U(1)$  symmetry (as for  $\alpha$  constant one finds  $\delta_\alpha S = 0$ ), recognizing at the same time the associated Noether current

$$J^\mu = i\phi^* \partial^\mu \phi - i(\partial^\mu \phi^*) \phi \equiv i\phi^* \overleftrightarrow{\partial}^\mu \phi\quad (54)$$

as the term multiplying  $\partial_\mu \alpha$ . It satisfies a continuity equation,  $\partial_\mu J^\mu = 0$ , a relation that can be verified by using the equations of motion. This happens as the equations of motion arise by setting  $\delta S[\phi, \phi^*] = 0$ , which is true for any variation around the classical solution, and in particular for those used to obtain (53). Thus, the equations of motion allow setting (53) to zero. Then, the arbitrariness of the function  $\alpha(x)$  allows deducing that  $\partial_\mu J^\mu = 0$ . We have applied Noether's method to find the conserved current, as discussed in more detail in appendix A.

The conserved charge corresponding to the current  $J^\mu$  is

$$Q \equiv \int d^3x J^0 = -i \int d^3x \phi^* \overleftrightarrow{\partial}_0 \phi\quad (55)$$

and is not positive definite: as already described it cannot have a probabilistic interpretation. Note that, inspired by this conservation law and the mathematics behind it, one defines a scalar product between any two solutions of the Klein-Gordon equation, say  $\chi$  and  $\phi$ , as

$$\langle \chi | \phi \rangle \equiv \int d^3x i \chi^* \overleftrightarrow{\partial}_0 \phi . \quad (56)$$

This scalar product is conserved, as verified by using the equations of motion.

The symmetries generated by the Poincaré group

$$\begin{aligned} x^\mu &\longrightarrow x'^\mu = \Lambda^\mu{}_\nu x^\nu + a^\mu \\ \phi(x) &\longrightarrow \phi'(x') = \phi(x) \\ \phi^*(x) &\longrightarrow \phi'^*(x') = \phi^*(x) \end{aligned} \quad (57)$$

transform the Klein-Gordon field as a scalar. It is easy to verify the invariance of the action under these finite transformations. It is also useful to study the case of infinitesimal transformations, from which one may extract the conserved currents with the Noether method. For an infinitesimal translation  $a^\mu$  eq. (57) reduces to

$$\begin{aligned} \delta_a \phi(x) &= \phi'(x) - \phi(x) = -a^\mu \partial_\mu \phi(x) \\ \delta_a \phi^*(x) &= \phi'^*(x) - \phi^*(x) = -a^\mu \partial_\mu \phi^*(x) . \end{aligned} \quad (58)$$

Considering now the parameter  $a^\mu$  as an arbitrary infinitesimal function we obtain the corresponding Noether's currents (the energy-momentum tensor  $T^{\mu\nu}$ ) by varying the action

$$\delta_{a(x)} S[\phi, \phi^*] = \int d^4x (\partial_\mu a_\nu) \underbrace{\left( \partial^\mu \phi^* \partial^\nu \phi + \partial^\nu \phi^* \partial^\mu \phi + \eta^{\mu\nu} \mathcal{L} \right)}_{T^{\mu\nu}} \quad (59)$$

where we have dropped total derivatives and where  $\mathcal{L}$  indicates the lagrangian density given in (44). The energy-momentum tensor  $T^{\mu\nu}$  is conserved,  $\partial_\mu T^{\mu\nu} = 0$ . The conserved charges are

$$P^\mu = \int d^3x T^{0\mu} \quad (60)$$

corresponding to the total momentum carried by the field. In particular, the energy density is given by

$$\mathcal{E}(x) = T^{00} = \partial_0 \phi^* \partial_0 \phi + \vec{\nabla} \phi^* \cdot \vec{\nabla} \phi + m^2 \phi^* \phi \quad (61)$$

and the total energy  $P^0 \equiv E = \int d^3x \mathcal{E}(x)$  is conserved and manifestly positive definite.

## 4 Spin $\frac{1}{2}$ : Dirac equation

Dirac found the correct equation to describe particles of spin  $\frac{1}{2}$  by looking for a relativistic wave equation that could admit a probabilistic interpretation, and thus be consistent with the principles of quantum mechanics. The Klein-Gordon equation did not have such an interpretation. Although a probabilistic interpretation will not be possible in the presence of interactions, (eventually Dirac's wave function must be treated as a classical field to be quantized again in second quantization), it is useful to retrace the line of thinking that brought Dirac to the formulation of an equation of first order in time

$$(\gamma^\mu \partial_\mu + m)\psi(x) = 0 \quad (62)$$

where the wave function  $\psi(x)$  has four complex components (a Dirac spinor) and the  $\gamma^\mu$  are  $4 \times 4$  matrices. Because the components of the Dirac wave function  $\psi(x)$  are not that of a four-vector (they mix differently under Lorentz transformations), it is necessary to use different indices to indicate their components without ambiguities. In this context we use indices  $\mu, \nu, \dots = 0, 1, 2, 3$  to indicate the components of a four-vector and indices  $a, b, \dots = 1, 2, 3, 4$  to indicate the components of a Dirac spinor. The equation (62) is then written more explicitly as

$$\left( (\gamma^\mu)_{a^b} \partial_\mu + m \delta_a^b \right) \psi_b(x) = 0 \quad (63)$$

and consists of four distinct coupled equations ( $a = 1, \dots, 4$ ). Spinorial indices are usually left implicit and a matrix notation is used:  $\gamma^\mu$  are matrices and  $\psi$  a column vector.

### Dirac equation

The relativistic relationship between energy and momentum for a free particle reads

$$p^\mu p_\mu = -m^2 c^2 \quad \Longleftrightarrow \quad E^2 = c^2 \vec{p}^2 + m^2 c^4 \quad (64)$$

and the substitutions

$$E = cp^0 \rightsquigarrow i\hbar \frac{\partial}{\partial t}, \quad \vec{p} \rightsquigarrow -i\hbar \frac{\partial}{\partial \vec{x}} \quad \Longleftrightarrow \quad p_\mu \rightsquigarrow -i\hbar \partial_\mu \quad (65)$$

lead to the Klein-Gordon equation that is second order in time: as a consequence the conserved  $U(1)$  current does not have a positive definite charge density to be interpreted as probability density. Thus, Dirac proposed a linear relationship of the form

$$E = c\vec{p} \cdot \vec{\alpha} + mc^2\beta \quad (66)$$

where  $\vec{\alpha}$  and  $\beta$  are hermitian matrices devised in such a way to allow consistency with the quadratic relation in (64). By squaring the linear relation one finds

$$\begin{aligned} E^2 &= (cp^i \alpha^i + mc^2\beta)(cp^j \alpha^j + mc^2\beta) \\ &= c^2 p^i p^j \alpha^i \alpha^j + m^2 c^4 \beta^2 + mc^3 p^i (\alpha^i \beta + \beta \alpha^i) \\ &= c^2 p^i p^j \frac{1}{2} (\alpha^i \alpha^j + \alpha^j \alpha^i) + m^2 c^4 \beta^2 + mc^3 p^i (\alpha^i \beta + \beta \alpha^i) \end{aligned} \quad (67)$$

and consistency with (64) for arbitrary momenta  $p^i$  requires that

$$\alpha^i \alpha^j + \alpha^j \alpha^i = 2\delta^{ij} \mathbb{1}, \quad \beta^2 = \mathbb{1}, \quad \alpha^i \beta + \beta \alpha^i = 0 \quad (68)$$

where  $\mathbb{1}$  is the identity matrix (it is often left implicit on the left side of (66) and (67)). These relationships define what is called a Clifford algebra. Dirac got a minimal solution for  $\vec{\alpha}$  and  $\beta$  with  $4 \times 4$  matrices. An explicit solution in terms of  $2 \times 2$  blocks is given by

$$\alpha^i = \begin{pmatrix} 0 & \sigma^i \\ \sigma^i & 0 \end{pmatrix}, \quad \beta = \begin{pmatrix} \mathbb{1} & 0 \\ 0 & -\mathbb{1} \end{pmatrix} \quad (69)$$

where  $\sigma^i$  are the Pauli matrices, i.e.  $2 \times 2$  matrices given by

$$\sigma^1 = \begin{pmatrix} 0 & 1 \\ 1 & 0 \end{pmatrix}, \quad \sigma^2 = \begin{pmatrix} 0 & -i \\ i & 0 \end{pmatrix}, \quad \sigma^3 = \begin{pmatrix} 1 & 0 \\ 0 & -1 \end{pmatrix} \quad (70)$$

that satisfy  $\sigma^i \sigma^j = \delta^{ij} \mathbb{1} + i\epsilon^{ijk} \sigma^k$ . This solution is called the Dirac representation. Note that  $\vec{\alpha}$  and  $\beta$  are traceless matrices.

A theorem, which we shall not prove, states that *all four dimensional irreducible representations of the Clifford algebra are unitarily equivalent to the Dirac one*, while other nontrivial representations are reducible.

Quantizing the relation (66) with (65) produces the Dirac equation in “hamiltonian” form

$$i\hbar\partial_t \psi = \underbrace{(-i\hbar c \vec{\alpha} \cdot \vec{\nabla} + mc^2 \beta)}_{H_D} \psi \quad (71)$$

where the hamiltonian  $H_D$  is a  $4 \times 4$  matrix of differential operators. The hermitian matrices  $\alpha^i$  and  $\beta$  guarantee hermiticity of the hamiltonian  $H_D$ , and therefore a unitary time evolution. Multiplying this equation by  $\frac{1}{\hbar c} \beta$  and defining the gamma matrices

$$\gamma^0 \equiv -i\beta, \quad \gamma^i \equiv -i\beta\alpha^i \quad (72)$$

brings the Dirac equation in the so-called “covariant” form

$$(\gamma^\mu \partial_\mu + \mu)\psi = 0 \quad (73)$$

where  $\mu = \frac{mc}{\hbar}$  is the inverse (reduced) Compton wavelength associated with the mass  $m$ . The fundamental relationships that define the gamma matrices are obtained from (68) and can be written using the anticommutator ( $\{A, B\} \equiv AB + BA$ ) as

$$\{\gamma^\mu, \gamma^\nu\} = 2\eta^{\mu\nu}. \quad (74)$$

In the Dirac representation the gamma matrices take the form

$$\gamma^0 = -i\beta = -i \begin{pmatrix} \mathbb{1} & 0 \\ 0 & -\mathbb{1} \end{pmatrix}, \quad \gamma^i = -i\beta\alpha^i = \begin{pmatrix} 0 & -i\sigma^i \\ i\sigma^i & 0 \end{pmatrix}. \quad (75)$$

We will use units with  $\hbar = c = 1$ , so that  $\mu = m$  and the Dirac equation looks as in (62). A useful notation introduced by Feynman ( $\not{\partial} \equiv \gamma^\mu \partial_\mu$ ) allows to write it also as

$$(\not{\partial} + m)\psi = 0. \quad (76)$$

### Continuity equation

It is immediate to derive an equation of continuity describing the conservation of a positive definite charge. Dirac tentatively identified the relative charge density, appropriately normalized, with a probability density.

Let us see how to get the continuity equation algebraically. Using the hamiltonian form, we multiply (71) with  $\psi^\dagger$  on the left and subtract the hermitian-conjugated equation multiplied by  $\psi$  on the right, and obtain (remember that  $\vec{\alpha}$  and  $\beta$  are hermitian matrices)

$$\psi^\dagger \left( i\hbar\partial_t \psi - (-i\hbar c \vec{\alpha} \cdot \vec{\nabla} + mc^2 \beta)\psi \right) - \left( -i\hbar\partial_t \psi^\dagger - (i\hbar c \vec{\nabla} \psi^\dagger \cdot \vec{\alpha} + \psi^\dagger mc^2 \beta) \right) \psi = 0,$$

the term mass simplifies and the rest combines into an equation of continuity

$$\partial_t(\psi^\dagger \psi) + \vec{\nabla} \cdot (c\psi^\dagger \vec{\alpha} \psi) = 0. \quad (77)$$



The charge density is positive defined,  $\psi^\dagger\psi > 0$ , and was initially related to a probability density.

### Properties of gamma matrices

The matrices  $\beta$  and  $\alpha^i$  are hermitian and guarantee the hermiticity of the Dirac hamiltonian. They are  $4 \times 4$  traceless matrices (in four dimensions). The corresponding  $\gamma^\mu$  matrices ( $\gamma^0 = -i\beta$  e  $\gamma^i = -i\beta\alpha^i$ ) satisfy a Clifford's algebra of the form

$$\{\gamma^\mu, \gamma^\nu\} = 2\eta^{\mu\nu} \quad (78)$$

with

$$(\gamma^0)^\dagger = -\gamma^0, \quad (\gamma^i)^\dagger = \gamma^i \quad (79)$$

i.e.  $\gamma^0$  is antihermitian and  $\gamma^i$  hermitian. These hermiticity relations can be written in a compact way as

$$(\gamma^\mu)^\dagger = \gamma^0\gamma^\mu\gamma^0 \quad (80)$$

or equivalently as

$$(\gamma^\mu)^\dagger = -\beta\gamma^\mu\beta. \quad (81)$$

One may easily prove that the gamma matrices have a vanishing trace. This is evident inspecting their explicit form in the Dirac representation, see eqs. (69) and (75), but it is useful to see this fact as arising from the algebraic properties of the gamma matrices. For example,

$$\text{tr } \gamma^1 = \text{tr } \gamma^1(\gamma^2)^2 = -\text{tr } \gamma^2\gamma^1\gamma^2 = -\text{tr } \gamma^1(\gamma^2)^2 = -\text{tr } \gamma^1 \Rightarrow \text{tr } \gamma^1 = 0 \quad (82)$$

where it is used that  $\gamma^1$  and  $\gamma^2$  anticommute, and the cyclic property of the trace.

Many properties of the gamma matrices are derivable using only the Clifford algebra, without resorting to their explicit representation.

It is also useful to introduce the chirality matrix  $\gamma^5$ , defined by

$$\gamma^5 = -i\gamma^0\gamma^1\gamma^2\gamma^3 \quad (83)$$

which satisfies the following properties

$$\{\gamma^5, \gamma^\mu\} = 0, \quad (\gamma^5)^2 = \mathbb{1}, \quad (\gamma^5)^\dagger = \gamma^5, \quad \text{tr}(\gamma^5) = 0. \quad (84)$$

In the Dirac representation (69) it takes the form (using  $2 \times 2$  block)

$$\gamma^5 = \begin{pmatrix} 0 & -\mathbb{1} \\ -\mathbb{1} & 0 \end{pmatrix}. \quad (85)$$

It is used to define the chiral projectors

$$P_L = \frac{\mathbb{1} - \gamma^5}{2}, \quad P_R = \frac{\mathbb{1} + \gamma^5}{2} \quad (86)$$

(they are projectors since  $P_L + P_R = \mathbb{1}$ ,  $P_L^2 = P_L$ ,  $P_R^2 = P_R$ ,  $P_L P_R = 0$ ), which allow the Dirac spinor to be divided into its left and right-handed components:  $\psi = \psi_L + \psi_R$  where  $\psi_L = P_L\psi$  and  $\psi_R = P_R\psi$ . As we shall see later, these chiral components (called Weyl spinors) transform independently under the Lorentz transformations (connected to the identity)  $SO^+(1,3)$

The gamma matrices act in spinor space, a four-dimensional complex vector space. Linear operators on spinor space are four-dimensional matrices, and the gamma matrices are just an

example. It is useful to consider a complete basis of these linear operators, which in turn form a 16-dimensional vector space (16 is the number of independent components of a  $4 \times 4$  matrix). A basis is the following one

$$(\mathbb{1}, \gamma^\mu, \Sigma^{\mu\nu}, \gamma^\mu \gamma^5, \gamma^5) \quad (87)$$

where  $\Sigma^{\mu\nu} \equiv -\frac{i}{4}[\gamma^\mu, \gamma^\nu]$ , that indeed form a set of  $1 + 4 + 6 + 4 + 1 = 16$  linearly independent matrices. Alternatively, the basis can be presented in a way that generalizes easily to arbitrary even spacetime dimensions

$$(\mathbb{1}, \gamma^\mu, \gamma^{\mu\nu}, \gamma^{\mu\nu\lambda}, \gamma^{\mu\nu\lambda\rho}) \quad (88)$$

where

$$\gamma^{\mu_1\mu_2\dots\mu_n} \equiv \frac{1}{n!}(\gamma^{\mu_1}\gamma^{\mu_2}\dots\gamma^{\mu_n} \pm \text{permutations}) \quad (89)$$

denotes completely antisymmetric products of gamma matrices (even permutations are added and odd permutations subtracted).

## Solutions

The free equation admits plane wave solutions which contains the phase  $e^{ip_\mu x^\mu}$  for propagation in space-time and a polarization  $w(p)$  for the spin.

Inserting in the Dirac equation a plane wave ansatz of the form

$$\psi_p(x) \sim w(p)e^{ip_\mu x^\mu}, \quad w(p) = \begin{pmatrix} w_1(p) \\ w_2(p) \\ w_3(p) \\ w_4(p) \end{pmatrix}, \quad p_\mu \text{ arbitrary} \quad (90)$$

one may see that the polarization must satisfy an algebraic equation  $((i\gamma^\mu p_\mu + m)w(p) = 0)$  with an on-shell momentum ( $p_\mu p^\mu = -m^2$ ). There give four solutions, two with “positive energy” (electrons with spin up and down) and two with “negative energy” (eventually to be identified with positrons with spin up and down).

Let us see the details. We insert the plane wave ansatz into the Dirac equation and find ( $\not{p} \equiv \gamma^\mu p_\mu$ )

$$(i\not{p} + m)w(p) = 0 \quad (91)$$

then we multiply by  $(-i\not{p} + m)$

$$(-i\not{p} + m)(i\not{p} + m)w(p) = (\not{p}^2 + m^2)w(p) = (p_\mu p^\mu + m^2)w(p) = 0 \quad (92)$$

which implies  $p_\mu p^\mu + m^2 = 0$ . Thus, it follows that there are solutions with both positive and negative energies, as in Klein-Gordon.

To develop intuition, we consider explicitly the case of particle at rest with  $p^\mu = (E, 0, 0, 0)$ . Eq. (91) becomes

$$0 = (i\gamma^0 p_0 + m)w(p) = (-i\gamma^0 E + m)w(p) = (-\beta E + m)w(p) \quad (93)$$

and it follows that  $Ew(p) = m\beta w(p)$ , i.e. recalling the explicit form of  $\beta$  in (69)

$$E w(p) = \begin{pmatrix} m & 0 & 0 & 0 \\ 0 & m & 0 & 0 \\ 0 & 0 & -m & 0 \\ 0 & 0 & 0 & -m \end{pmatrix} w(p). \quad (94)$$

Thus, there are two independent solutions with positive energy ( $E = m$ )

$$\psi_1(x) = \begin{pmatrix} 1 \\ 0 \\ 0 \\ 0 \end{pmatrix} e^{-imt}, \quad \psi_2(x) = \begin{pmatrix} 0 \\ 1 \\ 0 \\ 0 \end{pmatrix} e^{-imt} \quad (95)$$

and two independent solutions with negative energy ( $E = -m$ )

$$\psi_3(x) = \begin{pmatrix} 0 \\ 0 \\ 1 \\ 0 \end{pmatrix} e^{imt}, \quad \psi_4(x) = \begin{pmatrix} 0 \\ 0 \\ 0 \\ 1 \end{pmatrix} e^{imt}. \quad (96)$$

The general case with arbitrary momentum can be derived with similar calculations, or obtained from a Lorentz transformation applied to the above solution. In order to use the last method it is necessary to study explicitly the covariance of the Dirac equation, which we postpone for a while.

### Non-relativistic limit and Pauli equation

To study the non-relativistic limit of the Dirac equation we reinsert  $\hbar$  and  $c$ . It is convenient to use the hamiltonian form

$$i\hbar\partial_t\psi = (c\vec{\alpha} \cdot \vec{p} + mc^2\beta)\psi \quad (97)$$

where  $\vec{p} = -i\hbar\vec{\nabla}$ . To proceed, we cast the spinor wave function in the form

$$\psi(\vec{x}, t) = e^{-\frac{i}{\hbar}mc^2t} \begin{pmatrix} \varphi(\vec{x}, t) \\ \chi(\vec{x}, t) \end{pmatrix} \quad (98)$$

factoring out an expected time dependence due to the energy of the particle at rest (the mass), and splitting the Dirac spinor into two-component spinors  $\varphi$  and  $\chi$ . By inserting (98) into (97), and using (69), one gets for the two-dimensional spinors the coupled equations

$$i\hbar\partial_t\varphi = c\vec{\sigma} \cdot \vec{p}\chi \quad (99)$$

$$mc^2\chi + i\hbar\partial_t\chi = c\vec{\sigma} \cdot \vec{p}\varphi - mc^2\chi. \quad (100)$$

In the second one we can ignore the term with the time dependence  $\partial_t\chi$ , which is supposed to be due to the remaining kinetic energy, that in the nonrelativistic limit is small compared to the mass energy, thus obtaining an algebraic equation easily solved by

$$\chi = \frac{\vec{\sigma} \cdot \vec{p}}{2mc}\varphi. \quad (101)$$

Inserting it into the first equation produces

$$i\hbar\partial_t\varphi = \frac{(\vec{\sigma} \cdot \vec{p})^2}{2m}\varphi. \quad (102)$$

As  $(\vec{\sigma} \cdot \vec{p})^2 = \vec{p}^2$ , one finds a free Schrödinger equation for the two-component spinor  $\varphi$

$$i\hbar\partial_t\varphi = \frac{\vec{p}^2}{2m}\varphi \quad (103)$$

known as the free Pauli equation.

This analysis can be repeated considering the coupling to an electromagnetic field, to study explicitly effects due to the spin. We introduce the coupling by the minimal substitution  $p_\mu \rightarrow p_\mu - \frac{e}{c}A_\mu(x)$ , where  $e$  is the electric charge ( $e < 0$  for the electron). Since  $p^\mu = (\frac{E}{c}, \vec{p})$  and  $A^\mu = (\Phi, \vec{A})$ , with  $\Phi$  and  $\vec{A}$  the the scalar and vector potentials, respectively, the substitution translates into

$$E \rightarrow E - e\Phi, \quad \vec{p} \rightarrow \vec{p} - \frac{e}{c}\vec{A} \equiv \vec{\pi} \quad (104)$$

which inserted into the Dirac linear relation gives

$$E = c\vec{\alpha} \cdot \vec{\pi} + mc^2\beta + e\Phi \quad (105)$$

and thus the Dirac equation coupled to the electromagnetic field with potential  $A_\mu$

$$i\hbar\partial_t\psi = (c\vec{\alpha} \cdot \vec{\pi} + mc^2\beta + e\Phi)\psi \quad (106)$$

where  $\vec{\pi} = -i\hbar(\vec{\nabla} - \frac{ie}{\hbar c}\vec{A})$  is now a differential operator. Let us insert again the parameterization (98) of  $\psi$  into the equation and find

$$i\hbar\partial_t\varphi = c\vec{\sigma} \cdot \vec{\pi}\chi + e\Phi\varphi \quad (107)$$

$$mc^2\chi + i\hbar\partial_t\chi = c\vec{\sigma} \cdot \vec{\pi}\varphi - mc^2\chi + e\Phi\chi. \quad (108)$$

In the second equation we can neglect the time dependence on the left-hand side, negligible in the nonrelativistic limit, and the contribution of the term due to the electric potential on the right-hand side, negligible with respect to the mass (i.e. we ignore all terms small for  $c \rightarrow \infty$ ). We get again an algebraic equation for  $\chi$ , solved by

$$\chi = \frac{\vec{\sigma} \cdot \vec{\pi}}{2mc}\varphi \quad (109)$$

which substituted into the first equation gives

$$i\hbar\partial_t\varphi = \left( \frac{(\vec{\sigma} \cdot \vec{\pi})^2}{2m} + e\Phi \right) \varphi. \quad (110)$$

The algebra of Pauli matrices ( $\sigma^i\sigma^j = \delta^{ij}\mathbb{1} + i\epsilon^{ijk}\sigma^k$ ) allows to compute

$$(\vec{\sigma} \cdot \vec{\pi})^2 = \pi^i\pi^j\sigma^i\sigma^j = \vec{\pi}^2 + i\epsilon^{ijk}\pi^i\pi^j\sigma^k \quad (111)$$

where

$$i\epsilon^{ijk}\pi^i\pi^j\sigma^k = i\epsilon^{ijk}\frac{1}{2}[\pi^i, \pi^j]\sigma^k = i\epsilon^{ijk}\frac{1}{2}\frac{i\hbar e}{c}(\partial^i A^j - \partial^j A^i)\sigma^k = -\frac{\hbar e}{c}B^k\sigma^k. \quad (112)$$

The relevant calculation here is

$$\begin{aligned} [\pi^i, \pi^j] &= \left[ p^i - \frac{e}{c}A^i(x), p^j - \frac{e}{c}A^j(x) \right] = -\frac{e}{c}[p^i, A^j(x)] - (i \leftrightarrow j) \\ &= \frac{e}{c}[i\hbar\partial^i, A^j(x)] - (i \leftrightarrow j) = \frac{i\hbar e}{c}(\partial^i A^j - \partial^j A^i). \end{aligned} \quad (113)$$

Introducing the Pauli spin operator  $\vec{S} = \frac{1}{2}\hbar\vec{\sigma}$ , we write the above term as

$$(\vec{\sigma} \cdot \vec{\pi})^2 = \vec{\pi}^2 - \frac{2e}{c}\vec{S} \cdot \vec{B} \quad (114)$$

and the equation becomes

$$i\hbar\partial_t\varphi = \left( \frac{\vec{\pi}^2}{2m} - \frac{e}{mc}\vec{S}\cdot\vec{B} + e\Phi \right) \varphi \quad (115)$$

known as the Pauli equation. It was introduced by Pauli to take account in the Schrödinger equation the spin of a non-relativistic electron. As we have proved, it emerges naturally from the non-relativistic limit of the Dirac equation. In particular, the Dirac equation predicts a gyromagnetic ratio with  $g = 2$ . In this regard, it is useful to remember that a magnetic dipole  $\vec{\mu}$  couples to the magnetic field  $\vec{B}$  with a term in the Hamiltonian of the form

$$H = -\vec{\mu}\cdot\vec{B}.$$

A charge  $e$  in motion with angular momentum  $\vec{L}$  produces a magnetic dipole  $\vec{\mu}$  with

$$\frac{|\vec{\mu}|}{|\vec{L}|} = \frac{e}{2mc}g$$

where  $g = 1$  is the classic gyromagnetic factor. Dirac equation produces instead a gyromagnetic factor  $g = 2$ , associated with the intrinsic spin of the electron.

These considerations can be recovered also in the following way. Consider a constant magnetic field  $\vec{B}$ , described by the vector potential  $\vec{A} = \frac{1}{2}\vec{B}\times\vec{r}$ . Expanding the term  $\vec{\pi}^2$  in (115) one finds a term proportional to the angular momentum  $\vec{L} = \vec{r}\times\vec{p}$ , and the Pauli equation takes the form

$$i\hbar\partial_t\varphi = \left( \frac{\vec{p}^2}{2m} - \frac{e}{2mc}(\vec{L} + 2\vec{S})\cdot\vec{B} + \frac{e^2}{2mc^2}\vec{A}^2 + e\Phi \right) \varphi \quad (116)$$

from which we recognize the gyromagnetic factor  $g = 2$  of the dipole moment associated with the spin of the electron, and the  $g = 1$  factor associated with the magnetic moment due to the orbital motion.

### Angular momentum and spin

As seen from the non-relativistic limit, the Dirac spinor describes a particle of spin 1/2, such as the electron. The spin operator acts on the two components of the wave function  $\varphi$ , and is proportional to the Pauli matrices  $\vec{S} = \frac{\hbar}{2}\vec{\sigma}$ . This suggests that the full spin operator acting on the four-component Dirac spinor is given in the Dirac representation by

$$\vec{S} = \frac{1}{2}\vec{\Sigma} = \frac{1}{2} \begin{pmatrix} \vec{\sigma} & 0 \\ 0 & \vec{\sigma} \end{pmatrix} \quad (117)$$

(we return to  $\hbar = 1$ ). Indeed, from eq. (109) one recognizes that the lowest component  $\chi$  is related to the upper component  $\varphi$  by an operator that is a scalar under rotations, and thus  $\chi$  must carry the same spin representation (spin  $\frac{1}{2}$ ) of  $\varphi$  under the rotation group. The matrices  $\vec{\Sigma}$  can be written also as

$$\Sigma^i = -\frac{i}{2}\epsilon^{ijk}\alpha^j\alpha^k \quad (118)$$

which is in a form that is now valid in any representation of the Dirac matrices.

The orbital angular momentum  $\vec{L}$  is defined as usual by the operatorial version of

$$\vec{L} = \vec{r}\times\vec{p}. \quad (119)$$

The total angular momentum  $\vec{J} = \vec{L} + \vec{S}$  is conserved in case of rotational symmetry. Let us check this conservation in the free case. Using the hamiltonian form of the Dirac equation (71) we calculate

$$[H_D, L^i] = [\alpha^l p_l + \beta m, \epsilon^{ijk} x^j p^k] = -i\epsilon^{ijk} \alpha^j p^k \quad (120)$$

and <sup>1</sup>

$$[H_D, S^i] = \left[ \alpha^l p_l + \beta m, -\frac{i}{4} \epsilon^{ijk} \alpha^j \alpha^k \right] = -i\epsilon^{ijk} p^j \alpha^k \quad (121)$$

so that the total angular momentum is conserved

$$[H_D, J^i] = [H_D, L^i + S^i] = 0 . \quad (122)$$

## Hydrogen atom and Dirac equation

A crucial test for the Dirac equation was to check its predictions for the quantized energy levels of the hydrogen atom. The problem is exactly solvable. Nevertheless, it is illuminating to study perturbatively the solution for the energy levels, and compare it with the non-relativistic solution of the Schrödinger equation. The energies obtained from the Schrödinger, Klein-Gordon, and Dirac equations are

$$E_{nl}^{(S)} = -\frac{m_e \alpha^2}{2n^2} \quad (123)$$

$$E_{nl}^{(KG)} = m_e \left[ 1 - \frac{\alpha^2}{2n^2} - \frac{\alpha^4}{n^4} \left( \frac{n}{2l+1} - \frac{3}{8} \right) + O(\alpha^6) \right] \quad (124)$$

$$E_{nl}^{(D)} = m_e \left[ 1 - \frac{\alpha^2}{2n^2} - \frac{\alpha^4}{n^4} \left( \frac{n}{2j+1} - \frac{3}{8} \right) + O(\alpha^6) \right] \quad (125)$$

where  $\alpha = \frac{e^2}{4\pi} \sim \frac{1}{137}$  is the fine structure constant. In the last formula  $j = l \pm \frac{1}{2}$  if the orbital angular momentum carries  $l > 0$ , and  $j = l + \frac{1}{2}$  if  $l = 0$ . The Schrödinger non-relativistic result has the main quantum number  $n = 1, 2, 3, \dots, \infty$ , and degeneration in  $l = 0, 1, \dots, n-1$  (as  $n-l$  must be a strictly positive integer,  $n-l > 0$ ). The degeneration<sup>2</sup> in  $l$  is broken by relativistic effects (“fine structure” effects), but the Klein-Gordon prediction is in contradiction with the experimental results (seen in the Paschen spectroscopic series):  $2l+1$  is an odd integer, but that number is experimentally measured to be even. The prediction from the Dirac equation gives instead a result compatible with experiments, since now  $2j+1$  is even<sup>3</sup>.

We are not going to review in these notes the explicit derivation of the spectrum and related eigenfunctions. However, we wish to indicate how the KG and Dirac spectra are obtained from the Schrödinger one, carrying out substitutions (for further details, one may consult Itzykson Zuber, “QFT”, pag. 71-78, and the historical account in Weinberg, “QFT-vol I” pag. 3-14).

The eigenvalue problem of the Schrödinger equation for an electron in the Coulomb field of a proton (the nucleus of the hydrogen atom) takes the form

$$\hat{H}\psi_{nlm} = E_{nl}\psi_{nlm} , \quad \hat{H} = -\frac{1}{2m_e}\nabla^2 - \frac{e^2}{4\pi r} \quad (126)$$

<sup>1</sup>Using the identity  $[A, BC] = \{A, B\}C - B\{A, C\}$ .

<sup>2</sup>There is an additional degeneration in the magnetic quantum number  $m$ , common to all three cases.

<sup>3</sup>Additional effects exist but are smaller. The most important ones are the hyperfine structure, due to the interaction of the electron with the magnetic moment of the nucleus, and the “Lamb shift”, which breaks the degeneracy in  $j$ , due to quantum corrections obtainable by using the Dirac field as a QFT.

where  $n, l, m$  are the usual quantum numbers (the degeneration in the magnetic quantum number  $m$  is expected from spherical symmetry). Writing the laplacian in spherical coordinates  $\nabla^2 = \frac{1}{r^2} \partial_r r^2 \partial_r - \frac{\vec{L}^2}{r^2}$  with  $\vec{L}$  the angular momentum operator (recall that  $\vec{L}^2$  has eigenvalues  $l(l+1)$  with non-negative integer  $l$ ), the eigenvalue equation takes the explicit form

$$\left[ -\frac{1}{2m_e} \frac{1}{r^2} \partial_r r^2 \partial_r + \frac{1}{2m_e} \frac{\vec{L}^2}{r^2} - \frac{\alpha}{r} - E_{nl} \right] \psi_{nlm} = 0 \quad (127)$$

where  $\alpha = \frac{e^2}{4\pi}$ . It is well-known that the eigenvalues are degenerate also in  $l$ , and given by

$$E_{nl} = -\frac{m_e \alpha^2}{2} \frac{1}{n^2}, \quad n = 1, 2, \dots, \infty, \quad l = 0, 1, 2, \dots, n-1, \quad m = l, l-1, \dots, -l. \quad (128)$$

The spectrum in the quantum number  $l$  is truncated, as  $n-l$  must be strictly positive.

Let us now study the case of the Klein-Gordon equation. With the minimal substitution  $p_\mu \rightarrow p_\mu - eA_\mu = -i(\partial_\mu - ieA_\mu) = -iD_\mu$ , where  $D_\mu$  is known as the covariant derivative, the free Klein-Gordon equation  $(-\partial^\mu \partial_\mu + m_e^2)\phi = 0$  for a spinless electron takes the form

$$(-D^\mu D_\mu + m_e^2)\phi = 0. \quad (129)$$

For the time-independent KG equation, one resubstitutes  $E$  for the time derivative  $i\partial_t$ , and setting to zero the vector potential  $\vec{A}$  one finds only the minimal substitution  $E \rightarrow E - e\Phi = E + \frac{\alpha}{r}$ , which introduces the Coulomb potential, and the KG equation takes the form

$$\left[ -\left(E + \frac{\alpha}{r}\right)^2 - \nabla^2 + m_e^2 \right] \phi = 0. \quad (130)$$

In spherical coordinates it becomes

$$\left[ -\frac{1}{r^2} \partial_r r^2 \partial_r + \frac{\vec{L}^2 - \alpha^2}{r^2} - \frac{2E\alpha}{r} - (E^2 - m_e^2) \right] \phi = 0. \quad (131)$$

Now, compare this with eq. (127). The KG equation can be obtained from the Schrödinger's one by the substitutions

$$\begin{aligned} \vec{L}^2 = l(l+1) &\rightarrow \vec{L}^2 - \alpha^2 = l(l+1) - \alpha^2 \equiv \lambda(\lambda+1) \\ \alpha &\rightarrow \frac{\alpha E}{m_e} \\ E &\rightarrow \frac{E^2 - m_e^2}{2m_e}. \end{aligned} \quad (132)$$

Thus, one can also obtain its eigenvalues. As  $l(l+1) \rightarrow \lambda(\lambda+1)$ , we set  $\lambda = l - \delta_l$  and compute

$$\delta_l = \left(l + \frac{1}{2}\right) \left(1 - \sqrt{1 - \left(\frac{\alpha}{l + \frac{1}{2}}\right)^2}\right) = \frac{\alpha^2}{2l+1} + O(\alpha^4). \quad (133)$$

Now, as  $n-l$  must be a positive integer, and since  $l \rightarrow \lambda = l - \delta_l$ , also  $n$  must undergo a similar shift,  $n \rightarrow \nu = n - \delta_l$ , to keep  $n-l \rightarrow \nu - \lambda$  a positive integer. Finally, performing the substitutions (132) on the eigenvalues (128) we obtain

$$\frac{E_{nl}^2 - m_e^2}{2m_e} = -\frac{m_e}{2} \frac{\alpha^2 E_{nl}^2}{m_e^2} \frac{1}{(n - \delta_l)^2}, \quad n = 0, 1, 2, \dots, \infty \quad (134)$$

from which we get

$$E_{nl} = m_e \left( 1 + \frac{\alpha^2}{(n - \delta_l)^2} \right)^{-\frac{1}{2}}. \quad (135)$$

Expanded for small  $\delta_l$  it produces the Klein-Gordon spectrum, anticipated in eq. (124).

A similar procedure can be applied to the Dirac equation. With the minimal coupling one finds

$$(\gamma^\mu D_\mu + m_e)\psi = 0 \quad (136)$$

where  $D_\mu = \partial_\mu - ieA_\mu$ . The spinor  $\psi$  satisfies also a Klein-Gordon equation, but with an additional non-minimal coupling (from the Klein-Gordon perspective)

$$(\gamma^\mu D_\mu - m_e)(\gamma^\mu D_\mu + m_e)\psi = \left[ D^\mu D_\mu - \frac{ie}{2} F_{\mu\nu} \gamma^\mu \gamma^\nu - m_e^2 \right] \psi = 0. \quad (137)$$

The additional (non-minimal) term in the Klein-Gordon equation is

$$-\frac{ie}{2} F_{\mu\nu} \gamma^\mu \gamma^\nu = -ie \vec{E} \cdot \vec{\alpha} \quad (138)$$

as only the electric field of the Coulomb potential is present in the minimal substitution. Now one may show (we will not do it here) that its effect is just to modify  $l$  into  $j$  in the previous formula, with  $j = l \pm \frac{1}{2}$  if  $l > 0$ , and  $j = l + \frac{1}{2}$  if  $l = 0$ . This gives the spectrum of the Dirac equation given in eq. (125). The experimental data are shown in the figure below (taken from Itzykson-Zuber, recall the notation  $^{2s+1}L_j$  with the  $2s + 1 = 2$  neglected for the spin of the electron).

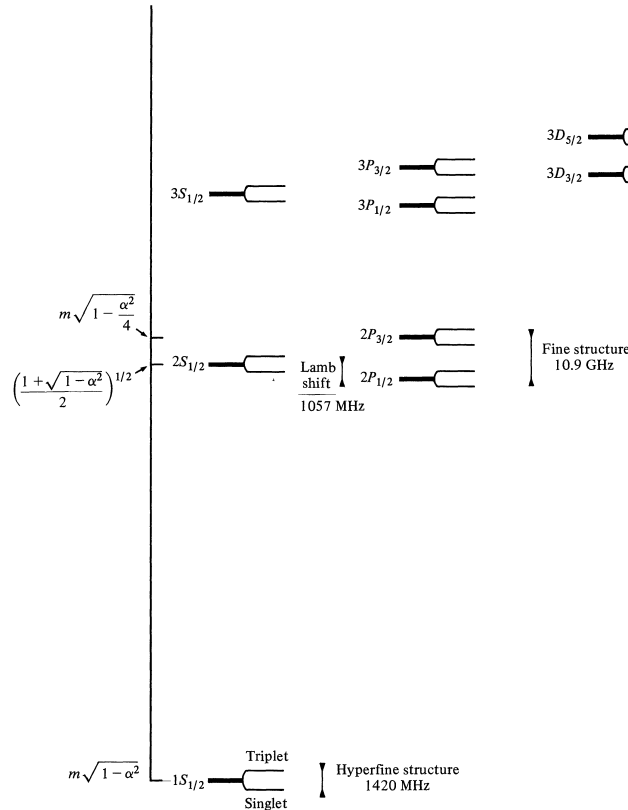

Figure 2-2 Low-lying energy levels of hydrogen.



## Covariance

The Dirac equation, derived from relativistic considerations, is consistent with relativistic invariance. To prove it explicitly it is necessary to show that the equation is invariant in form under a change of inertial frame of reference as generated by a proper and orthochronous Lorentz transformation. Recall that by Lorentz invariance one generically refers only to the transformations that are continuously connected to the identity, leaving out the discrete transformations of parity  $P$  and time reversal  $T$  which are treated separately.

Thus, we need to construct the precise transformation of the Dirac spinor  $\psi(x)$  under a Lorentz transformation  $\Lambda$ . One may conjecture it to be linear and of the form

$$\psi(x) \longrightarrow \psi'(x') = S(\Lambda)\psi(x) \quad (139)$$

so that a Lorentz transformation acts as

$$\begin{array}{ccc} (\gamma^\mu \partial_\mu + m)\psi(x) = 0 & \iff & (\gamma^\mu \partial'_\mu + m)\psi'(x') = 0 \\ x^\mu & & x'^\mu = \Lambda^\mu{}_\nu x^\nu \\ \partial_\mu & & \partial'_\mu = \Lambda_\mu{}^\nu \partial_\nu \\ \psi(x) & & \psi'(x') = S(\Lambda)\psi(x) . \end{array}$$

Relating the second reference frame to the first, and multiplying by  $S^{-1}(\Lambda)$ , we see that one equation is equivalent to the other one if  $S(\Lambda)$  satisfies the relation

$$S^{-1}(\Lambda)\gamma^\mu S(\Lambda)\Lambda_\mu{}^\nu = \gamma^\nu \quad (140)$$

or equivalently<sup>4</sup>, after multiplying with  $\Lambda^\rho{}_\nu$  and renaming indices,

$$S^{-1}(\Lambda)\gamma^\mu S(\Lambda) = \Lambda^\mu{}_\nu \gamma^\nu . \quad (141)$$

To verify that such  $S(\Lambda)$  exists, it is sufficient to consider infinitesimal transformations

$$\begin{aligned} \Lambda^\mu{}_\nu &= \delta^\mu{}_\nu + \omega^\mu{}_\nu & \text{with } \omega_{\mu\nu} &= -\omega_{\nu\mu} & (\Lambda = \mathbb{1} + \omega \text{ in matrix form}) \\ S(\Lambda) &= \mathbb{1} + \frac{i}{2}\omega_{\mu\nu}\Sigma^{\mu\nu} \end{aligned} \quad (142)$$

where  $\Sigma^{\mu\nu} = -\Sigma^{\nu\mu}$  indicate the six  $4 \times 4$  matrices that act on spinors. These are the generators of the Lorentz transformations on spinors. Substituting them into (140), or (141), one finds

$$[\Sigma^{\mu\nu}, \gamma^\rho] = i(\eta^{\mu\rho}\gamma^\nu - \eta^{\nu\rho}\gamma^\mu) \quad (143)$$

which is an algebraic equation for  $\Sigma^{\mu\nu}$ . It is solved by

$$\Sigma^{\mu\nu} = -\frac{i}{4}[\gamma^\mu, \gamma^\nu] . \quad (144)$$

---

<sup>4</sup>Note that  $\Lambda_\mu{}^\nu$  acts on vectors with lower indices: it is obtained by raising/lowering indices on  $\Lambda^\mu{}_\nu$  so that it corresponds to the matrix  $\eta\Lambda\eta^{-1} = \Lambda^{-1,T}$ . The last relation follows from the defining property  $\Lambda^T\eta\Lambda = \eta$ . Then, one may check that  $\Lambda^\rho{}_\nu\Lambda_\mu{}^\nu = [\Lambda(\eta\Lambda\eta^{-1})^T]^\rho{}_\mu = [\Lambda\Lambda^{-1}]^\rho{}_\mu = \delta^\rho{}_\mu$ .

This proves Lorentz invariance of the Dirac equation. Finite transformations are obtained by iterating infinitesimal ones. Eq. (144) is verified by a direct calculation.

To gain familiarity with equation (143), one may test it by choosing some values for the indices. For example, setting  $(\mu, \nu, \rho) = (1, 2, 2)$  gives

$$[\Sigma^{12}, \gamma^2] = -i\gamma^1. \quad (145)$$

To verify that (144) satisfies it we compute

$$\Sigma^{12} = -\frac{i}{4}[\gamma^1, \gamma^2] = -\frac{i}{2}\gamma^1\gamma^2 \quad (146)$$

and

$$[\Sigma^{12}, \gamma^2] = -\frac{i}{2}[\gamma^1\gamma^2, \gamma^2] = -\frac{i}{2}(\gamma^1\gamma^2\gamma^2 - \gamma^2\gamma^1\gamma^2) = -i\gamma^1. \quad (147)$$

In general, using the Clifford algebra one may compute

$$\begin{aligned} [\Sigma^{\mu\nu}, \gamma^\rho] &= -\frac{i}{4}[(\gamma^\mu\gamma^\nu - \gamma^\nu\gamma^\mu), \gamma^\rho] = -\frac{i}{4}[\gamma^\mu\gamma^\nu, \gamma^\rho] - (\mu \leftrightarrow \nu) \\ &= -\frac{i}{4}(\gamma^\mu\{\gamma^\nu, \gamma^\rho\} - \{\gamma^\mu, \gamma^\rho\}\gamma^\nu) - (\mu \leftrightarrow \nu) \\ &= -\frac{i}{2}(\gamma^\mu\eta^{\nu\rho} - \eta^{\mu\rho}\gamma^\nu) - (\mu \leftrightarrow \nu) \\ &= i(\eta^{\mu\rho}\gamma^\nu - \eta^{\nu\rho}\gamma^\mu). \end{aligned} \quad (148)$$

For finite transformations, one may use the exponential parameterization

$$S(\Lambda) = e^{\frac{i}{2}\omega_{\mu\nu}\Sigma^{\mu\nu}} = e^{\frac{1}{4}\omega_{\mu\nu}\gamma^\mu\gamma^\nu}. \quad (149)$$

### Examples

Transformations with  $\omega_{12} = -\omega_{21} = \varphi$  produce rotations around the  $z$  axis. If the parameter  $\varphi$  is finite

$$\omega^\mu{}_\nu = \varphi \begin{pmatrix} 0 & & & \\ & 0 & 1 & \\ & -1 & 0 & \\ & & & 0 \end{pmatrix} \Rightarrow \Lambda^\mu{}_\nu = (e^\omega)^\mu{}_\nu = \begin{pmatrix} 1 & & & \\ & \cos \varphi & \sin \varphi & \\ & -\sin \varphi & \cos \varphi & \\ & & & 1 \end{pmatrix} \quad (150)$$

and from (149)

$$\begin{aligned} S(\Lambda) &= \exp\left(\frac{i}{2}\omega_{\mu\nu}\Sigma^{\mu\nu}\right) = \exp\left(\frac{1}{4}\omega_{\mu\nu}\gamma^\mu\gamma^\nu\right) = \exp\left(\frac{\varphi}{2}\gamma^1\gamma^2\right) \\ &= \exp\left(\frac{i\varphi}{2}\begin{pmatrix} \sigma^3 & 0 \\ 0 & \sigma^3 \end{pmatrix}\right) = \begin{pmatrix} e^{\frac{i\varphi}{2}} & & & \\ & e^{-\frac{i\varphi}{2}} & & \\ & & e^{\frac{i\varphi}{2}} & \\ & & & e^{-\frac{i\varphi}{2}} \end{pmatrix} \end{aligned} \quad (151)$$

where we used the Dirac representation of the gamma matrices. The transformation is immediately recognized to be unitary,  $S^\dagger(\Lambda) = S^{-1}(\Lambda)$ . It is also clear that it is a spinorial

transformation, which is double valued: the rotation with  $\varphi = 2\pi$  (that coincides with the identity on vectors) is represented by  $-1$  on the spinors. It is necessary to make a rotation of  $4\pi$  to get back the identity.

Similarly, a rotation of an angle  $\varphi$  around an axis  $\hat{n}$  is represented on the spinors by

$$S(\Lambda) = \begin{pmatrix} e^{i\frac{\varphi}{2}\hat{n}\cdot\vec{\sigma}} & 0 \\ 0 & e^{i\frac{\varphi}{2}\hat{n}\cdot\vec{\sigma}} \end{pmatrix} \quad (152)$$

and easily checked to be unitary. Now, going back to eq. (98) used in the non-relativistic limit of the Dirac equation we may appreciate how the four-dimensional Dirac spinor is decomposed in terms of the two nonrelativistic spinors  $\phi$  and  $\chi$  and how the spin operator (117) acts on them.

A boost along  $x$  is generated by  $\omega_{01} = -\omega_{10} \equiv \omega$ , which for finite values gives

$$\Lambda^\mu{}_\nu = \begin{pmatrix} \cosh \omega & -\sinh \omega & & \\ -\sinh \omega & \cosh \omega & & \\ & & 1 & \\ & & & 1 \end{pmatrix} = \begin{pmatrix} \gamma & -\beta\gamma & & \\ -\beta\gamma & \gamma & & \\ & & 1 & \\ & & & 1 \end{pmatrix} \quad (153)$$

and we identify the usual parameters  $\gamma = \cosh \omega$  and  $\beta = \tanh \omega$  (the parameter  $\omega$  is often called *rapidity*, it is additive for boosts along the same direction, while velocities add in a more complicated way). On spinors this boost is represented by

$$\begin{aligned} S(\Lambda) &= \exp\left(\frac{i}{2}\omega_{\mu\nu}\Sigma^{\mu\nu}\right) = \exp\left(\frac{1}{4}\omega_{\mu\nu}\gamma^\mu\gamma^\nu\right) = \exp\left(\frac{\omega}{2}\gamma^0\gamma^1\right) \\ &= \exp\left(-\frac{\omega}{2}\alpha^1\right) = \mathbb{1} \cosh \frac{\omega}{2} - \alpha^1 \sinh \frac{\omega}{2}. \end{aligned} \quad (154)$$

Note that this transformation is not unitary, but satisfies  $S^\dagger(\Lambda) = S(\Lambda)$ .

The previous boost transformation can be written and generalized as follows. Using hyperbolic trigonometric identities, and using  $(E, \vec{p}) = (m\gamma, m\vec{\beta}\gamma)$ , one finds

$$\begin{aligned} \tanh \frac{\omega}{2} &= \frac{\sinh \omega}{1 + \cosh \omega} = \frac{\beta\gamma}{1 + \gamma} = \frac{|\vec{p}|}{m + E} \\ \cosh \frac{\omega}{2} &= \sqrt{\frac{1}{2}(1 + \cosh \omega)} = \sqrt{\frac{1}{2}(1 + \gamma)} = \sqrt{\frac{m + E}{2m}} \end{aligned} \quad (155)$$

so that we can first rewrite

$$S(\Lambda) = \cosh \frac{\omega}{2} \left( \mathbb{1} - \alpha^1 \tanh \frac{\omega}{2} \right), \quad (156)$$

then generalize to a boost in an arbitrary direction  $\frac{\vec{v}}{|\vec{v}|}$  by using  $\alpha^1 \rightarrow \frac{\vec{\alpha}\cdot\vec{v}}{|\vec{v}|}$ , and finally change the direction of the boost ( $\omega \rightarrow -\omega$ ) so that by acting on a spinor at rest we get the spinor moving with velocity  $\vec{v}$  (and momentum  $\vec{p}$ ). The final transformation takes the form

$$S(\Lambda) = \sqrt{\frac{m + E}{2m}} \left( \mathbb{1} + \frac{\vec{\alpha}\cdot\vec{p}}{m + E} \right) \quad (157)$$

and applied to the spinors (95) and (96) produce the general plane wave solutions of the Dirac equation. We obtain the positive energy solutions (the columns of the matrix  $S(\Lambda)$  times the plane wave)

$$\psi_1(x) = \sqrt{\frac{m+E}{2m}} \begin{pmatrix} 1 \\ 0 \\ \frac{p_3}{m+E} \\ \frac{p_+}{m+E} \end{pmatrix} e^{ip_\mu x^\mu}, \quad \psi_2(x) = \sqrt{\frac{m+E}{2m}} \begin{pmatrix} 0 \\ 1 \\ \frac{p_-}{m+E} \\ -\frac{p_3}{m+E} \end{pmatrix} e^{ip_\mu x^\mu} \quad (158)$$

and the negative energy solution

$$\psi_3(x) = \sqrt{\frac{m+E}{2m}} \begin{pmatrix} \frac{p_3}{m+E} \\ \frac{p_+}{m+E} \\ 1 \\ 0 \end{pmatrix} e^{-ip_\mu x^\mu}, \quad \psi_4(x) = \sqrt{\frac{m+E}{2m}} \begin{pmatrix} \frac{p_-}{m+E} \\ -\frac{p_3}{m+E} \\ 0 \\ 1 \end{pmatrix} e^{-ip_\mu x^\mu} \quad (159)$$

where  $p^\mu = (E, \vec{p})$  with  $E = \sqrt{\vec{p}^2 + m^2} > 0$ , and  $p_\pm = p_1 \pm ip_2$ .

### Pseudo-unitarity

The spinorial representation in (149) is not unitary,  $S^\dagger(\Lambda) \neq S^{-1}(\Lambda)$ , as seen in the particular example of the Lorentz boost. This is understandable in the light of a theorem according to which *unitary irreducible representations of compact groups are finite-dimensional, while those of non-compact groups are infinite-dimensional*. Lorentz's group is non-compact because of the boosts.

However, the spinorial representations are pseudo-unitary, in the sense that

$$S^\dagger(\Lambda) = \beta S^{-1}(\Lambda) \beta. \quad (160)$$

Indeed, using  $\gamma^{\mu\dagger} = -\beta\gamma^\mu\beta$ , one may compute

$$\Sigma^{\mu\nu\dagger} = \left( -\frac{i}{4} [\gamma^\mu, \gamma^\nu] \right)^\dagger = \frac{i}{4} [\gamma^{\nu\dagger}, \gamma^{\mu\dagger}] = -\frac{i}{4} [\gamma^{\mu\dagger}, \gamma^{\nu\dagger}] = \beta \Sigma^{\mu\nu} \beta \quad (161)$$

from which it follows (for matrices can still use  $e^A = 1 + A + \frac{1}{2}A^2 + \dots + \frac{1}{n!}A^n + \dots$ )

$$S^\dagger(\Lambda) = \left( e^{\frac{i}{2}\omega_{\mu\nu}\Sigma^{\mu\nu}} \right)^\dagger = e^{-\frac{i}{2}\omega_{\mu\nu}\Sigma^{\mu\nu\dagger}} = e^{-\frac{i}{2}\omega_{\mu\nu}\beta\Sigma^{\mu\nu}\beta} = \beta e^{-\frac{i}{2}\omega_{\mu\nu}\Sigma^{\mu\nu}} \beta = \beta S^{-1}(\Lambda) \beta. \quad (162)$$

### Transformations of fermionic bilinears

Given the previous result, it is useful to define the spinor  $\bar{\psi}(x)$ , called the Dirac conjugate of the spinor  $\psi(x)$ , defined by

$$\bar{\psi}(x) = \psi^\dagger(x) \beta \quad (163)$$

that transforms as

$$\bar{\psi}'(x') = \bar{\psi}(x) S^{-1}(\Lambda). \quad (164)$$

This is easily verified

$$\bar{\psi}'(x') = \psi'^\dagger(x') \beta = (S(\Lambda)\psi(x))^\dagger \beta = \psi^\dagger(x) S^\dagger(\Lambda) \beta = \psi^\dagger(x) \beta S^{-1}(\Lambda) \beta^2 = \bar{\psi}(x) S^{-1}(\Lambda). \quad (165)$$

Then it follows that the bilinear  $\bar{\psi}(x)\psi(x)$  is a scalar under  $SO^+(1, 3)$

$$\bar{\psi}'(x')\psi'(x') = \bar{\psi}(x)S(\Lambda)S^{-1}(\Lambda)\psi(x) = \bar{\psi}(x)\psi(x). \quad (166)$$

The quantity  $\psi^\dagger\psi$  instead is not a scalar, but identifies the time-component of the four-vector  $J^\mu = (J^0, \vec{J}) = (\psi^\dagger\psi, \psi^\dagger\vec{\alpha}\psi)$ , which is the current that appears in the continuity equation (77). It can be written in a manifestly covariant form as

$$J^\mu = i\bar{\psi}\gamma^\mu\psi. \quad (167)$$

Its transformation laws are indeed that of a four-vector

$$\begin{aligned} J'^\mu(x') &= i\bar{\psi}'(x')\gamma^\mu\psi'(x') = i\bar{\psi}(x)S^{-1}(\Lambda)\gamma^\mu S(\Lambda)\psi(x) = \Lambda^\mu{}_\nu i\bar{\psi}(x)\gamma^\nu\psi(x) \\ &= \Lambda^\mu{}_\nu J^\nu(x) \end{aligned} \quad (168)$$

where we used (141).

The quantities  $\bar{\psi}\psi$  and  $\bar{\psi}\gamma^\mu\psi$  are examples of *fermionic bilinears*, quantities that furnish useful expressions for describing physical properties of the spin 1/2 relativistic particle.

Quite generally, using the basis of the spinor space  $\Gamma^A = (\mathbb{1}, \gamma^\mu, \Sigma^{\mu\nu}, \gamma^\mu\gamma^5, \gamma^5)$ , one may define fermionic bilinears of the form

$$\bar{\psi}\Gamma^A\psi \quad (169)$$

which transform as scalar, vector, antisymmetric tensor of rank 2, pseudovector, pseudoscalar, respectively. We have already discussed the first two cases. For the pseudoscalar (neglecting for notational simplicity the dependence on the spacetime point) we find

$$(\bar{\psi}\gamma^5\psi)' = \bar{\psi}S(\Lambda)\gamma^5S^{-1}(\Lambda)\psi = \bar{\psi}\gamma^5\psi \quad (170)$$

that indeed we recognize to be a scalar under proper and orthochronous Lorentz transformations (the adjective ‘‘pseudo’’ refers to a different behavior under spatial reflection, i.e. under a parity transformation). As last example we consider the antisymmetric tensor

$$\begin{aligned} (\bar{\psi}\Sigma^{\mu\nu}\psi)' &= \bar{\psi}S(\Lambda)\left(-\frac{i}{4}[\gamma^\mu, \gamma^\nu]\right)S^{-1}(\Lambda)\psi = \bar{\psi}\left(-\frac{i}{4}[S(\Lambda)\gamma^\mu S^{-1}(\Lambda), S(\Lambda)\gamma^\nu S^{-1}(\Lambda)]\right)\psi \\ &= \Lambda^\mu{}_\rho\Lambda^\nu{}_\sigma\bar{\psi}\Sigma^{\rho\sigma}\psi. \end{aligned} \quad (171)$$

where we have used (141).

## Remarks on covariance

In proving covariance, we obtained the spinorial representation<sup>5</sup>  $S(\Lambda)$  of the Lorentz group

$$\begin{aligned} x^\mu &\longrightarrow x^{\mu'} = \Lambda^\mu{}_\nu x^\nu \\ \psi(x) &\longrightarrow \psi'(x') = S(\Lambda)\psi(x) \end{aligned} \quad (172)$$

that for infinitesimal transformations  $\Lambda^\mu{}_\nu = \delta^\mu{}_\nu + \omega^\mu{}_\nu$  takes the form

$$S(\Lambda) = \mathbb{1} + \frac{i}{2}\omega_{\mu\nu}\Sigma^{\mu\nu} \quad (173)$$

where the generators  $\Sigma^{\mu\nu} = -\frac{i}{4}[\gamma^\mu, \gamma^\nu]$  are built from the gamma matrices. They realize the Lie algebra of the Lorentz group<sup>6</sup>

$$[\Sigma^{\mu\nu}, \Sigma^{\lambda\rho}] = -i\eta^{\nu\lambda}\Sigma^{\mu\rho} + i\eta^{\mu\lambda}\Sigma^{\nu\rho} + i\eta^{\nu\rho}\Sigma^{\mu\lambda} - i\eta^{\mu\rho}\Sigma^{\nu\lambda} \quad (179)$$

as shown by using the Clifford algebra to evaluate the commutators.

Before attempting to prove the general case, a simpler exercise is to check an example, as  $[\Sigma^{01}, \Sigma^{12}] = -i\Sigma^{02}$ . One finds  $\Sigma^{01} = -\frac{i}{4}[\gamma^0, \gamma^1] = -\frac{i}{2}\gamma^0\gamma^1$ ,  $\Sigma^{12} = -\frac{i}{2}\gamma^1\gamma^2$ ,  $\Sigma^{02} = -\frac{i}{2}\gamma^0\gamma^2$ , and calculates

$$\begin{aligned} [\Sigma^{01}, \Sigma^{12}] &= \left(-\frac{i}{2}\right)^2 [\gamma^0\gamma^1, \gamma^1\gamma^2] = -\frac{1}{4}(\gamma^0\gamma^1\gamma^1\gamma^2 - \gamma^1\gamma^2\gamma^0\gamma^1) \\ &= -\frac{1}{4}(\gamma^0\gamma^2 - \gamma^2\gamma^0) = -\frac{1}{2}\gamma^0\gamma^2 = -i\Sigma^{02}. \end{aligned} \quad (180)$$

Now one can verify the general case, also using for example the intermediate result in eq. (148).

---

<sup>5</sup>Two-valued representation.

<sup>6</sup>Let us review how to identify the Lie algebra of the Lorentz group. We write the infinitesimal transformations

$$\Lambda^\mu{}_\nu = \delta^\mu{}_\nu + \omega^\mu{}_\nu \quad (174)$$

in matrix form

$$\Lambda = \mathbb{1} + \omega = \mathbb{1} + \frac{i}{2}\omega_{\mu\nu}M^{\mu\nu} \quad (175)$$

to expose on the right hand side the six  $4 \times 4$  matrices  $M^{\mu\nu}$  (with  $M^{\nu\mu} = -M^{\mu\nu}$ ) that multiply the 6 independent coefficients  $\omega_{\mu\nu} = -\omega_{\nu\mu}$  that parametrize the Lorentz group. These 6 matrices evidently have the following matrix elements

$$(M^{\mu\nu})^\lambda{}_\rho = -i(\eta^{\mu\lambda}\delta^\nu{}_\rho - \eta^{\nu\lambda}\delta^\mu{}_\rho) \quad (176)$$

(just compare (174) with (175)). Now, a direct calculation produces the Lie algebra of the Lorentz group

$$[M^{\mu\nu}, M^{\lambda\rho}] = -i\eta^{\nu\lambda}M^{\mu\rho} + i\eta^{\mu\lambda}M^{\nu\rho} + i\eta^{\nu\rho}M^{\mu\lambda} - i\eta^{\mu\rho}M^{\nu\lambda}. \quad (177)$$

At this point, one can think of it as an abstract algebra, and may pose the problem of identifying its representations. Under exponentiation, they produce representations of the Lorentz group. The  $\Sigma^{\mu\nu} = -\frac{i}{4}[\gamma^\mu, \gamma^\nu]$  provide the spinorial representation of the abstract generators  $M^{\mu\nu}$  on a complex 4-component spinor (which, as we shall see, decomposes into the irreducible left-handed and right-handed 2-dimensional representations acting on chiral spinors). For finite transformations one writes

$$\begin{aligned} \Lambda(\omega) &= e^\omega = e^{\frac{i}{2}\omega_{\mu\nu}M^{\mu\nu}} \\ S(\Lambda(\omega)) &= e^{\frac{i}{2}\omega_{\mu\nu}\Sigma^{\mu\nu}} \end{aligned} \quad (178)$$

where the matrices  $M^{\mu\nu}$  are the generators in the defining representation given above.

From a group perspective, relation (140) indicates that the matrices  $\gamma^\mu$  are invariant tensors (Clebsch-Gordan coefficients). To understand this, let us rewrite (140) in the form

$$\Lambda^\mu{}_\nu S(\Lambda) \gamma^\nu S^{-1}(\Lambda) = \gamma^\mu$$

which is valid for any  $\Lambda \in SO^+(3,1)$ . This formula is interpreted as a transformation that operates on all the indices of  $\gamma^\mu$  (the vector index is explicit, while spinor indices are left implicit). The transformation leaves  $\gamma^\mu$  invariant

$$\gamma^\mu \longrightarrow \gamma^{\mu'} = \Lambda^\mu{}_\nu S(\Lambda) \gamma^\nu S^{-1}(\Lambda) = \gamma^\mu \quad (181)$$

which tells that  $\gamma^\mu$  is an invariant tensor, just like the metric  $\eta_{\mu\nu}$ .

With these group properties in mind, it is easy to understand the covariance of the Dirac equation

$$(\gamma^\mu \partial_\mu + m)\psi(x) = 0 \quad \iff \quad (\gamma^\mu \partial'_\mu + m)\psi'(x') = 0 \quad (182)$$

in the following way: exploiting the fact that gamma matrices are invariant tensors, one rewrites the left-hand side of the second equation with a transformed  $\gamma^{\mu'}$  (which is the same as  $\gamma^\mu$ ), and takes into account tensor calculus (contraction of upper indices with lower ones that produce scalars) to find

$$\begin{aligned} (\gamma^\mu \partial'_\mu + m)\psi'(x') &= (\gamma^{\mu'} \partial'_\mu + m)\psi'(x') \\ &= S(\Lambda)(\gamma^\mu \partial_\mu + m)\psi(x) \end{aligned} \quad (183)$$

and (182) follows. It is the same calculation as before, but reinterpreted by recognizing the transformation properties of tensors: covariance is manifest, and corresponds to the transformation of the spinor  $\chi(x) \equiv (\gamma^\mu \partial_\mu + m)\psi(x)$ : it transforms covariantly and equals zero in any inertial reference frames.

### Discrete symmetries: $P, T, C$

In addition to the Lorentz transformations connected to the identity, one can prove invariance of the free Dirac equation under discrete transformations such as spatial reflection  $P$  (also known as parity), time reversal  $T$ , and charge conjugation  $C$  which exchanges particles with antiparticles.

#### Parity $P$

Let us discuss the transformation that reverses the orientation of the spatial axes, i.e. parity

$$\begin{aligned} t &\xrightarrow{P} t' = t \\ \vec{x} &\xrightarrow{P} \vec{x}' = -\vec{x}. \end{aligned} \quad (184)$$

In tensorial notation

$$x^\mu \xrightarrow{P} x'^\mu = P^\mu{}_\nu x^\nu, \quad P^\mu{}_\nu = \begin{pmatrix} 1 & 0 & 0 & 0 \\ 0 & -1 & 0 & 0 \\ 0 & 0 & -1 & 0 \\ 0 & 0 & 0 & -1 \end{pmatrix}. \quad (185)$$

This is a discrete operation with  $\det(P^\mu{}_\nu) = -1$ . It belongs to the Lorentz group  $O(3,1)$ , but is not connected to the identity. Together with the identity it forms a subgroup isomorphic to

$Z_2 = \{1, -1\}$ . Invariance under parity can be studied by conjecturing an appropriate linear transformation of the spinor

$$\psi(x) \xrightarrow{P} \psi'(x') = \mathcal{P}\psi(x) \quad (186)$$

generated by a suitable matrix  $\mathcal{P}$ . Requiring invariance in form of the Dirac equation

$$\begin{aligned} (\gamma^\mu \partial_\mu + m)\psi(x) = 0 & \xleftrightarrow{P} (\gamma^\mu \partial'_\mu + m)\psi'(x') = 0 \\ x^\mu & \qquad \qquad \qquad x'^\mu = P^\mu{}_\nu x^\nu \\ \partial_\mu & \qquad \qquad \qquad \partial'_\mu = P^\nu{}_\mu \partial_\nu \\ \psi(x) & \qquad \qquad \qquad \psi'(x') = \mathcal{P}\psi(x) \end{aligned}$$

the form of  $\mathcal{P}$  is determined. Proceeding as for the Lorentz transformations  $S(\Lambda)$  one finds

$$\mathcal{P}^{-1} \gamma^\mu \mathcal{P} P_\mu{}^\nu = \gamma^\nu \quad (187)$$

or equivalently

$$\mathcal{P}^{-1} \gamma^\mu \mathcal{P} = P^\mu{}_\nu \gamma^\nu = \begin{pmatrix} \gamma^0 \\ -\gamma^i \end{pmatrix}. \quad (188)$$

A matrix  $\mathcal{P}$  that commutes with  $\gamma^0$  and anticommutes with  $\gamma^i$  is  $\gamma^0$  itself, or equivalently,  $\beta = i\gamma^0$ . Thus, one may choose  $\mathcal{P} = \eta_P \beta$  with  $\eta_P$  a phase fixed by requiring that  $\mathcal{P}^4$  coincides with the identity on fermions (so that the possible choices are  $\eta_P = (\pm 1, \pm i)$ ). For simplicity we choose  $\eta_P = 1$ , and use the parity transformations

$$\begin{aligned} \psi(x) & \xrightarrow{P} \psi'(x') = \beta\psi(x) \\ \bar{\psi}(x) & \xrightarrow{P} \bar{\psi}'(x') = \bar{\psi}(x)\beta. \end{aligned} \quad (189)$$

From these basic rules one deduces the transformations of the fermionic bilinears

$$\begin{aligned} \bar{\psi}(x)\psi(x) & \xrightarrow{P} \bar{\psi}'(x')\psi'(x') = \bar{\psi}(x)\psi(x) && \text{scalar} \\ \bar{\psi}(x)\gamma^5\psi(x) & \xrightarrow{P} \bar{\psi}'(x')\gamma^5\psi'(x') = -\bar{\psi}(x)\gamma^5\psi(x) && \text{pseudoscalar} \\ \bar{\psi}(x)\gamma^\mu\psi(x) & \xrightarrow{P} \bar{\psi}'(x')\gamma^\mu\psi'(x') = P^\mu{}_\nu \bar{\psi}(x)\gamma^\nu\psi(x) && \text{(polar) vector} \\ \bar{\psi}(x)\gamma^\mu\gamma^5\psi(x) & \xrightarrow{P} \bar{\psi}'(x')\gamma^\mu\gamma^5\psi'(x') = -P^\mu{}_\nu \bar{\psi}(x)\gamma^\nu\gamma^5\psi(x) && \text{axial vector} \\ \bar{\psi}(x)\Sigma^{\mu\nu}\psi(x) & \xrightarrow{P} \bar{\psi}'(x')\Sigma^{\mu\nu}\psi'(x') = P^\mu{}_\lambda P^\nu{}_\rho \bar{\psi}(x)\Sigma^{\lambda\rho}\psi(x) && \text{tensor.} \end{aligned} \quad (190)$$

### Chiral properties

Having understood how parity works, it is time to focus on the reducibility of a Dirac spinor under the proper and orthochronous Lorentz group  $SO^+(3, 1)$ . Using the projectors<sup>7</sup>

$$P_L = \frac{1 - \gamma_5}{2}, \quad P_R = \frac{1 + \gamma_5}{2} \quad (191)$$

one separates the Dirac spinor in left-handed and right-handed components

$$\psi = \psi_L + \psi_R, \quad \psi_L \equiv \frac{1 - \gamma_5}{2}\psi, \quad \psi_R \equiv \frac{1 + \gamma_5}{2}\psi. \quad (192)$$

<sup>7</sup>Hermitian matrices that satisfy  $P_L + P_R = \mathbf{1}$ ,  $P_L^2 = P_L$ ,  $P_R^2 = P_R$ ,  $P_L P_R = 0$ .



These chiral components constitute the two irreducible spin 1/2 representations of the Lorentz group. The irreducibility follows from the fact that the infinitesimal Lorentz generators  $\Sigma^{\mu\nu}$  commute with the projectors  $P_L$  and  $P_R$ , and thus also finite transformations must commute with the projectors. For example, considering  $P_L$  one can calculate

$$\Sigma^{\mu\nu} P_L = \left( -\frac{i}{4}[\gamma^\mu, \gamma^\nu] \right) \frac{1 - \gamma_5}{2} = \frac{1 - \gamma_5}{2} \left( -\frac{i}{4}[\gamma^\mu, \gamma^\nu] \right) = P_L \Sigma^{\mu\nu} \quad (193)$$

as  $\gamma^5$  commutes with an even number of gamma matrices, and likewise for  $P_R$ . The interpretation of this commutativity is that operating with an infinitesimal Lorentz rotation on a chiral spinor of given chirality produces a chiral spinor of the same chirality. More explicitly, considering infinitesimal transformations one verifies that the transformed spinor  $(\psi_L)'$  remains left-handed

$$\begin{aligned} \psi_L \xrightarrow{SO^+(3,1)} (\psi_L)' &= \left( 1 + \frac{i}{2} \omega_{\mu\nu} \Sigma^{\mu\nu} \right) \psi_L = \left( 1 + \frac{i}{2} \omega_{\mu\nu} \Sigma^{\mu\nu} \right) P_L \psi_L = P_L \left( 1 + \frac{i}{2} \omega_{\mu\nu} \Sigma^{\mu\nu} \right) \psi_L \\ &= P_L (\psi_L)' . \end{aligned} \quad (194)$$

Left-handed and right-handed spinors are called Weyl spinors, and they identify the two inequivalent, irreducible spinor representations of  $SO^+(3,1)$ .

Now let us consider parity. Including parity, the Dirac spinor is not reducible anymore. Parity transforms left-handed spinors into right-handed one, and viceversa. Recalling the parity transformation of a Dirac spinor,  $\psi \xrightarrow{P} \psi' = \beta\psi$ , one finds that a left-handed spinor is transformed into a right-handed one

$$\psi_L \xrightarrow{P} (\psi_L)' = \left( \frac{1 - \gamma_5}{2} \psi \right)' = \beta \left( \frac{1 - \gamma_5}{2} \psi \right) = \frac{1 + \gamma_5}{2} \beta\psi = \frac{1 + \gamma_5}{2} \psi' = (\psi')_R . \quad (195)$$

Both chiralities are needed to realize parity, which must exchange the two chiralities.

Additional remarks: *the representations of the Lorentz group can be systematically constructed using the fact that its Lie algebra can be written in terms of two commuting  $SU(2)$  subalgebras,  $SO^+(3,1) \sim SU(2) \times SU(2)$ . Taking advantage of the knowledge of the  $SU(2)$  representations, one can assign two integers or semi-integers quantum numbers  $(j, j')$  to indicate an irreducible representation of the Lorentz group. The irreps  $(\frac{1}{2}, 0)$  and  $(0, \frac{1}{2})$  correspond to the two chiral spinors described above (left-handed and right-handed Weyl spinors). They are inequivalent if parity is not considered. The Dirac spinor forms a reducible representation of  $SO^+(3,1)$  given by the direct sum  $(\frac{1}{2}, 0) \oplus (0, \frac{1}{2})$ . It becomes irreducible when considering the group  $O(3,1)$  that includes the parity transformation. Chiral theories (non-invariant under parity) can be constructed using Weyl fermions rather than Dirac fermions.*

Chirality is a Lorentz invariant concept. For massless fermions chirality is correlated to the helicity  $h$ , defined as the projection of the spin along the direction of motion

$$h = \frac{\vec{S} \cdot \vec{p}}{|\vec{p}|} . \quad (196)$$

Helicity is a Lorentz invariant concept only for massless particles. Let us consider a massless, left-handed fermion  $\psi_L = \frac{1 - \gamma_5}{2} \psi_L$ , which then satisfies  $\gamma^5 \psi_L = -\psi_L$ . It satisfies also the Dirac equation, which in momentum space (i.e. after a Fourier transform) reads

$$\not{p} \psi_L(p) = 0 . \quad (197)$$

The mass-shell condition is now  $p^\mu p_\mu = 0$ . Considering motion along the  $z$  direction, one has  $p^0 = p^3$  and  $p^1 = p^2 = 0$ , so that

$$0 = (\gamma^0 p_0 + \gamma^3 p_3) \psi_L(p) = p^0 (\gamma^3 - \gamma^0) \psi_L(p) \quad \rightarrow \quad \gamma^3 \psi_L(p) = \gamma^0 \psi_L(p). \quad (198)$$

Now, the spin along the  $z$  axis is given by

$$S^3 = \Sigma^{12} = -\frac{i}{4} [\gamma^1, \gamma^2] = -\frac{i}{2} \gamma^1 \gamma^2 \quad (199)$$

and it measures the helicity  $h$ ,  $S^3 = h$ . One computes it as follows

$$\begin{aligned} S^3 \psi_L(p) &= -\frac{i}{2} \gamma^1 \gamma^2 \psi_L(p) = \frac{i}{2} \gamma^0 \gamma^0 \gamma^1 \gamma^2 \psi_L(p) = \frac{i}{2} \gamma^0 \gamma^1 \gamma^2 \gamma^0 \psi_L(p) \\ &= \frac{i}{2} \gamma^0 \gamma^1 \gamma^2 \gamma^3 \psi_L(p) = -\frac{1}{2} \gamma^5 \psi_L(p) = \frac{1}{2} \psi_L(p). \end{aligned} \quad (200)$$

Thus,  $\psi_L$  describes a particle of helicity  $h = \frac{1}{2}$ . One may check that its antiparticle, described by the charge conjugated field  $\psi_{L,c}$  that is right-handed, has helicity  $h = -\frac{1}{2}$ .

When dealing with chiral fermions, it is often useful to employ a different representation of the gamma matrices, called the *chiral representation*. A chiral representation is identified by the fact that the chiral matrix  $\gamma^5$  is diagonal. A chiral representation is given by

$$\gamma^0 = i \begin{pmatrix} 0 & \mathbb{1} \\ \mathbb{1} & 0 \end{pmatrix}, \quad \gamma^i = -i \beta \alpha^i = \begin{pmatrix} 0 & -i \sigma^i \\ i \sigma^i & 0 \end{pmatrix}, \quad \gamma^5 = \begin{pmatrix} -\mathbb{1} & 0 \\ 0 & \mathbb{1} \end{pmatrix} \quad (201)$$

and is obtained from the Dirac representation by a similarity transformation (a change of basis) generated by a unitary matrix  $U$

$$\gamma_{(chiral)}^\mu = U \gamma_{(Dirac)}^\mu U^{-1} \quad (202)$$

where

$$U = \frac{1}{\sqrt{2}} \begin{pmatrix} \mathbb{1} & \mathbb{1} \\ -\mathbb{1} & \mathbb{1} \end{pmatrix}, \quad U^{-1} = \frac{1}{\sqrt{2}} \begin{pmatrix} \mathbb{1} & -\mathbb{1} \\ \mathbb{1} & \mathbb{1} \end{pmatrix}. \quad (203)$$

In the chiral representation the Lorentz generators  $\Sigma^{\mu\nu} = -\frac{i}{4} [\gamma^\mu, \gamma^\nu] = -\frac{i}{2} \gamma^{\mu\nu}$  are given by

$$\Sigma^{0i} = -\frac{i}{2} \gamma^{0i} = \frac{i}{2} \begin{pmatrix} \sigma^i & 0 \\ 0 & -\sigma^i \end{pmatrix}, \quad \Sigma^{ij} = -\frac{i}{2} \gamma^{ij} = \frac{1}{2} \epsilon^{ijk} \begin{pmatrix} \sigma^k & 0 \\ 0 & \sigma^k \end{pmatrix}. \quad (204)$$

The block-diagonal matrices of the Lorentz generators make it evident they act independently on the chiral parts of a Dirac spinor

$$\psi = \begin{pmatrix} \tilde{\psi}_L \\ \tilde{\psi}_R \end{pmatrix} \sim \begin{pmatrix} (\tilde{\psi}_L)_a \\ (\tilde{\psi}_R)_b \end{pmatrix} \quad (205)$$

where the two-component chiral spinors (*Weyl spinors*) are identified by

$$\psi_L = \begin{pmatrix} \tilde{\psi}_L \\ 0 \end{pmatrix}, \quad \psi_R = \begin{pmatrix} 0 \\ \tilde{\psi}_R \end{pmatrix}. \quad (206)$$

## Time reversal $T$

We now discuss time reversal

$$\begin{aligned} t &\xrightarrow{T} t' = -t \\ \vec{x} &\xrightarrow{T} \vec{x}' = \vec{x} \end{aligned} \quad (207)$$

i.e.

$$x^\mu \xrightarrow{T} x'^\mu = T^\mu{}_\nu x^\nu, \quad T^\mu{}_\nu = \begin{pmatrix} -1 & 0 & 0 & 0 \\ 0 & 1 & 0 & 0 \\ 0 & 0 & 1 & 0 \\ 0 & 0 & 0 & 1 \end{pmatrix}. \quad (208)$$

It is a discrete symmetry with  $\det(T^\mu{}_\nu) = -1$ . It belongs to  $O(3, 1)$ , but is not connected to the identity. Together with the identity it forms a subgroup isomorphic to  $Z_2 = \{1, -1\}$ . The way time reversal acts on spinors can be found by conjecturing a suitable anti-linear transformation on the spinor

$$\psi(x) \xrightarrow{T} \psi'(x') = \mathcal{T}\psi^*(x) \quad (209)$$

generated by a matrix  $\mathcal{T}$ . The complex conjugate is suggested by the non-relativistic limit that links the Dirac equation to the Schrödinger equation. The Schrödinger equation is known to have a time reversal symmetry, which acts by transforming the wave function to its complex conjugate one. Thus, requiring invariance

$$\begin{aligned} (\gamma^\mu \partial_\mu + m)\psi(x) = 0 &\quad \xleftrightarrow{T} \quad (\gamma^\mu \partial'_\mu + m)\psi'(x') = 0 \\ x^\mu &\quad x'^\mu = T^\mu{}_\nu x^\nu \\ \partial_\mu &\quad \partial'_\mu = T^\mu{}_\nu \partial_\nu \\ \psi(x) &\quad \psi'(x') = \mathcal{T}\psi^*(x), \end{aligned}$$

and comparing the latter with the complex conjugate of the former ( $\gamma^{\mu*} \partial_\mu + m)\psi^*(x) = 0$ ), one finds

$$\mathcal{T}^{-1} \gamma^\mu \mathcal{T} = T^\mu{}_\nu \gamma^{\nu*} = \begin{pmatrix} -\gamma^{0*} \\ \gamma^{1*} \\ \gamma^{2*} \\ \gamma^{3*} \end{pmatrix} = \begin{pmatrix} \gamma^0 \\ -\gamma^1 \\ \gamma^2 \\ -\gamma^3 \end{pmatrix}. \quad (210)$$

The last equality is obtained using the explicit Dirac representation of gamma matrices (75). Thus, one needs to find a matrix  $\mathcal{T}$  that commutes with  $\gamma^0$  and  $\gamma^2$  and anticommutes with  $\gamma^1$  and  $\gamma^3$ . This matrix is proportional to  $\gamma^1 \gamma^3$ . Adding an arbitrary phase  $\eta_T$  one finds

$$\mathcal{T} = \eta_T \gamma^1 \gamma^3. \quad (211)$$

For simplicity, one can set  $\eta_T = 1$ . Note that on spinors  $T^2 = -1$  and  $T^4 = 1$ .

## Hole theory

To overcome the problem of negative energy solutions, Dirac developed the theory of holes, abandoning the single-particle interpretation of his wave equation, and predicting the existence of antiparticles. He supposed that the vacuum state, defined as the state with lowest energy, consists in a configuration in which all the negative energy levels are occupied by electrons (the “Dirac sea”). Pauli’s exclusion principle guarantees that no more electrons can be added to the negative energy levels. This vacuum state has by definition vanishing energy and charge

$$E(vac) = 0 , \quad Q(vac) = 0 . \quad (212)$$

The state with one physical electron consists in an occupied positive energy level on top of the filled Dirac sea

$$E(electron) = E_p > 0 , \quad Q(electron) = e . \quad (213)$$

It has a charge  $e < 0$  (by convention) and cannot jump to a negative energy level because the negative energy levels are all occupied and the Pauli principle forbids the jump: the configuration is stable.

In addition, one can also imagine a configuration in which a negative energy level lacks its electron: this is a *hole* in the Dirac sea. It is equivalent to a configuration in which a particle with positive energy and charge  $-e$  is present on top of the vacuum: in fact, filling the hole with an electron with negative energy  $-E_p$  and charge  $e$  gives back the vacuum state with vanishing energy and charge.

$$\begin{aligned} E(hole) + (-E_p) = E(vac) = 0 & \quad \rightarrow \quad E(hole) = E_p > 0 \\ Q(hole) + e = Q(vac) = 0 & \quad \rightarrow \quad Q(hole) = -e . \end{aligned} \quad (214)$$

These considerations led Dirac to predict the existence of the positron, the antiparticle of the electron. Moreover, it becomes possible to imagine the phenomenon of *pair creation*: a photon that interacts with the vacuum can transfer its energy to an electron with negative energy, and bring it to positive energy, thus creating an electron and a hole, i.e. an electron/positron pair.

This interpretation has been of great use for physical intuition, though it is not directly applicable to bosonic systems (as Pauli’s principle is not valid for bosons). The correct realization of these ideas are implemented in QFT, both for fermions and bosons.

## Charge conjugation $C$

The Dirac equation can be coupled to electromagnetism with the minimal substitution  $p_\mu \rightarrow p_\mu - eA_\mu$ . It takes the form

$$(\gamma^\mu(\partial_\mu - ieA_\mu) + m)\psi = 0 \quad (215)$$

and describes particles with charge  $e$  and antiparticles with same mass but opposite charge  $-e$ , as suggested by the hole theory of Dirac. It should be possible to describe the same physics in terms of a Dirac equation for the antiparticles, identifying the original particles as anti-antiparticles. Evidently, the new equation must take the form

$$(\gamma^\mu(\partial_\mu + ieA_\mu) + m)\psi_c = 0 \quad (216)$$

where  $\psi_c$  denotes the charge conjugation of  $\psi$ . Thus, the existence of a discrete transformation which links  $\psi$  to  $\psi_c$  is expected on physical ground. This transformation is called *charge conjugation*. It exchanges particles and antiparticles. To identify it, one proceeds as follows.

One compares eq. (216) with the complex conjugate of (215), which becomes

$$(\gamma^{\mu*}(\partial_\mu + ieA_\mu) + m)\psi^* = 0 \quad (217)$$

so that the correct relative sign between  $\partial_\mu$  and  $ieA_\mu$  is achieved. Now, one searches for a matrix  $\mathcal{A}$  such that

$$\mathcal{A}\gamma^{\mu*}\mathcal{A}^{-1} = \gamma^\mu \quad (218)$$

so that the identification

$$\psi_c = \mathcal{A}\psi^* \quad (219)$$

realizes the required transformation. It is customary to write  $\mathcal{A}$  in the form

$$\mathcal{A} = \mathcal{C}\beta \quad (220)$$

where  $\mathcal{C}$  is called the charge conjugation matrix and (219) is written directly in terms of the Dirac conjugate  $\bar{\psi}$

$$\psi_c = \mathcal{A}\psi^* = \mathcal{C}\beta\psi^* = \mathcal{C}\bar{\psi}^T \quad (221)$$

where we have used that in the Dirac representation  $\beta$  is real and symmetric. Recalling that  $\gamma^{\mu\dagger} = -\beta\gamma^\mu\beta$  and taking the transpose, one finds  $\gamma^{\mu*} = -\beta\gamma^{\mu T}\beta$ , i.e.  $\beta\gamma^{\mu*}\beta = -\gamma^{\mu T}$ . This way (218) reduces to the requirement

$$\mathcal{C}\gamma^{\mu T}\mathcal{C}^{-1} = -\gamma^\mu \quad (222)$$

i.e.

$$\mathcal{C}^{-1}\gamma^\mu\mathcal{C} = -\gamma^{\mu T} = \begin{pmatrix} -\gamma^0 \\ \gamma^1 \\ -\gamma^2 \\ \gamma^3 \end{pmatrix}. \quad (223)$$

where we have used the Dirac representation (75), where  $\gamma^0$  and  $\gamma^2$  are symmetric, ( $\gamma^{0T} = \gamma^0$  and  $\gamma^{2T} = \gamma^2$ ) while  $\gamma^1$  and  $\gamma^3$  are antisymmetric ( $\gamma^{1T} = -\gamma^1$  and  $\gamma^{3T} = -\gamma^3$ ). Thus,  $\mathcal{C}$  must commute with  $\gamma^1$  and  $\gamma^3$  and anticommute with  $\gamma^0$  and  $\gamma^2$ . Then, one may take

$$\mathcal{C} = \gamma^0\gamma^2. \quad (224)$$

Note that  $\mathcal{C}$  is antisymmetric ( $\mathcal{C}^T = -\mathcal{C}$ ) and coincides with its inverse ( $\mathcal{C}^{-1} = \mathcal{C}$ ). Inserting an arbitrary phase  $\eta_C$ , one finds for the charge conjugation transformation of the Dirac spinor

$$\psi \xrightarrow{\mathcal{C}} \psi_c = \eta_C\mathcal{A}\psi^* = \eta_C\mathcal{C}\bar{\psi}^T \quad (225)$$

here written in two equivalent ways. The arbitrary phase is usually set to 1 for simplicity.

What we have described is not a true symmetry if one keeps the background  $A_\mu$  fixed, and thus one calls it “*background symmetry*”. It becomes a true symmetry when the field  $A_\mu$  is treated as a dynamical field, subject to its own equations of motion and to the transformation  $A_\mu \xrightarrow{\mathcal{C}} A_\mu^c = -A_\mu$ . This is then the charge conjugation symmetry of QED.

Finally, let us show that the charge conjugation of a left-handed spinor is right-handed (and viceversa): a direct computation gives

$$\psi_{L,c} = \mathcal{C}\bar{\psi}_L^T = \mathcal{C}(\bar{\psi}_L P_R)^T = \mathcal{C}P_R\bar{\psi}_L^T = P_R\mathcal{C}\bar{\psi}_L^T = P_R\psi_{L,c} \quad (226)$$

where we have used that in the Dirac basis  $\mathcal{C} = \gamma^0\gamma^2$ , and  $\gamma^{5T} = \gamma^5$  (i.e.  $P_R^T = P_R$ ).

## CPT

Although the discrete symmetries  $C$ ,  $P$ , and  $T$  of the free theory can be broken by interactions (notably by the weak interaction), the  $CPT$  combination is found to be always valid for theories which are Lorentz invariant (i.e. invariant under  $SO^+(3,1)$ ). The theorem that proves this statement is known as the “ $CPT$  theorem”, and will not be treated in these notes. In the case of a Dirac fermion the  $CPT$  transformation takes the form

$$\begin{aligned} x^\mu &\longrightarrow x'^\mu = -x^\mu \\ \psi(x) &\longrightarrow \psi_{CPT}(x') = \eta_{CPT}\gamma^5\psi(x) \end{aligned} \quad (227)$$

with  $\eta_{CPT}$  an arbitrary phase and one verifies quite easily the invariance of the free Dirac equation under it.

## Action

The action is of great value to study symmetries, interactions, and equations of motion. Moreover, it is the starting point for quantization, either canonical or by path integrals.

To identify an action for the Dirac equation, one insures Lorentz invariance by taking a scalar lagrangian density. The latter is constructed using the Dirac field  $\psi$  and its Dirac conjugate  $\bar{\psi} = \psi^\dagger\beta = \psi^\dagger i\gamma^0$ , which has the property of transforming in such a way to make the product  $\bar{\psi}\psi$  a scalar. Then, one recognizes that a suitable action is given by

$$S[\psi, \bar{\psi}] = \int d^4x \mathcal{L}, \quad \mathcal{L} = -\bar{\psi}(\gamma^\mu\partial_\mu + m)\psi. \quad (228)$$

It is a Lorentz scalar, and varying  $\bar{\psi}$  and  $\psi$  independently, one finds that the least action principle indeed produces the Dirac equation and its conjugated one

$$(\gamma^\mu\partial_\mu + m)\psi(x) = 0, \quad \bar{\psi}(x)(\gamma^\mu\overleftarrow{\partial}_\mu - m) = 0. \quad (229)$$

## Symmetries

The symmetries under the Lorentz group have already been described. The symmetries under space-time translations are verified by taking the spinor  $\psi(x)$  transforming as a scalar ( $\psi(x) \rightarrow \psi'(x') = \psi(x)$  under  $x^\mu \rightarrow x'^\mu = x^\mu + a^\mu$  with  $a^\mu$  constant). The related Noether current gives the energy-momentum tensor.

Let us consider in more details the internal symmetry generated by phase transformations

$$\begin{aligned} \psi(x) &\longrightarrow \psi'(x) = e^{i\alpha}\psi(x) \\ \bar{\psi}(x) &\longrightarrow \bar{\psi}'(x) = e^{-i\alpha}\bar{\psi}(x) \end{aligned} \quad (230)$$

forming the group  $U(1)$ . It is immediate to check that the action (228) is invariant. The infinitesimal version reads

$$\begin{aligned} \delta\psi(x) &= i\alpha\psi(x) \\ \delta\bar{\psi}(x) &= -i\alpha\bar{\psi}(x) \end{aligned} \quad (231)$$

and extending  $\alpha$  to an arbitrary function  $\alpha(x)$  we compute

$$\delta S[\psi, \bar{\psi}] = - \int d^4x (\partial_\mu \alpha) \underbrace{i\bar{\psi}\gamma^\mu\psi}_{J^\mu} \quad (232)$$

which verifies again the  $U(1)$  symmetry (for constant  $\alpha$ ), obtaining at the same time the Noether current

$$J^\mu = i\bar{\psi}\gamma^\mu\psi \quad (233)$$

which is conserved on-shell (i.e. using the equations of motion:  $\partial_\mu J^\mu = 0$ ). As already noticed, the conserved charge density is positive definite

$$J^0 = i\bar{\psi}\gamma^0\psi = i\psi^\dagger i\gamma^0\gamma^0\psi = \psi^\dagger\psi \geq 0 \quad (234)$$

and led Dirac to interpret it as a probability density. In second quantization, it is reinterpreted as the symmetry related to the fermionic number (its charge will count the number of particles minus the number of antiparticles), and in that context eq. (234) becomes an operator which is no longer positive definite. In the coupling to electromagnetism, it is related to the electric charge.

More generally, a collection of  $N$  Dirac fermions with the same Dirac mass, is invariant under the group  $U(N) = U(1) \times SU(N)$ . To see this, let us consider  $N$  fermions  $\psi^i$  transforming in the fundamental representation of  $U(N)$ , the  $N$  representation,

$$\psi^i \rightarrow \psi'^i = U^i_j \psi^j \quad U^i_j \in U(N) . \quad (235)$$

Then, the Dirac conjugates  $\bar{\psi}_i$  (basically the complex conjugate fields) transform in the anti-fundamental representation of  $U(N)$ , the  $\bar{N}$  representation,

$$\bar{\psi}_i \rightarrow \bar{\psi}'_i = \bar{\psi}_j (U^{-1})^j_i \quad (236)$$

and the lagrangian

$$\mathcal{L} = -\bar{\psi}_i (\gamma^\mu \partial_\mu + m) \psi^i \quad (237)$$

is manifestly invariant. The corresponding Noether currents

$$J^{\mu,a} = i\bar{\psi}_i \gamma^\mu (T^a)^i_j \psi^j , \quad a = 1, \dots, N^2 \quad (238)$$

are conserved  $\partial_\mu J^{\mu,a} = 0$ . They are derived by considering infinitesimal transformations  $U = e^{i\alpha^a T^a} = 1 + i\alpha^a T^a$  and extending the infinitesimal Lie parameters  $\alpha^a$  to be arbitrary functions, as usual.

If the mass vanishes the internal symmetry becomes larger, and given by the group  $U(2N)$ , as left and right handed fermions transforms independently. This fact may be better appreciated and proved after studying the properties of chiral fermions and their charge conjugation.

### Action for chiral fermions

Often one analyzes the action rather than the equations of motion to derive general properties of the system. Thus, it is interesting to study the action written in terms of the irreducible chiral components  $\psi_L$  and  $\psi_R$  and their Dirac conjugates. It takes the form

$$S[\psi_L, \bar{\psi}_L, \psi_R, \bar{\psi}_R] = \int d^4x \mathcal{L} , \quad \mathcal{L} = -\bar{\psi}_L \not{\partial} \psi_L - \bar{\psi}_R \not{\partial} \psi_R - m(\bar{\psi}_L \psi_R + \bar{\psi}_R \psi_L) \quad (239)$$

which is verified by recalling the properties of the projectors  $P_{L/R}$ , and in particular

$$\begin{aligned}\psi_L &= P_L \psi = \frac{\mathbb{1} - \gamma^5}{2} \psi = \frac{\mathbb{1} - \gamma^5}{2} \psi_L \\ \overline{\psi}_L &= \psi_L^\dagger \beta = \psi_L^\dagger \frac{\mathbb{1} - \gamma^5}{2} \beta = \psi_L^\dagger \beta \frac{\mathbb{1} + \gamma^5}{2} = \overline{\psi}_L \frac{\mathbb{1} + \gamma^5}{2} = \overline{\psi}_L P_R \\ \gamma^\mu P_L &= P_R \gamma^\mu \quad \left( \text{i.e. } \gamma^\mu \frac{\mathbb{1} \pm \gamma^5}{2} = \frac{\mathbb{1} \mp \gamma^5}{2} \gamma^\mu \right).\end{aligned}\tag{240}$$

The form of the action shows that the Dirac mass term  $m$  cannot be present for chiral fermions (i.e. in models where one keeps only  $\psi_L$  by setting  $\psi_R = 0$ , for example). Recall that the Dirac mass term had the property of being invariant under the  $U(1)$  phase transformations given in eq. (230)<sup>8</sup>.

However, there is one more Lorentz invariant mass term that is possible: the Majorana mass. It breaks the  $U(1)$  symmetry related to fermion number. It is used in extensions of the standard model that describe conjectured phenomena for neutrinos (such as the double beta decay without emission of neutrinos). It is of the form

$$\mathcal{L}_M = \frac{M}{2} \psi^T \mathcal{C}^{-1} \psi + h.c.\tag{241}$$

where  $M$  is the Majorana mass,  $\mathcal{C} = \gamma^0 \gamma^2$  is the charge conjugation matrix introduced in (224), and “*h.c.*” indicates hermitian conjugation. This term is Lorentz invariant, and therefore admissible. However, it breaks the  $U(1)$  fermion number symmetry of (230). Lorentz invariance is explicitly verified: under infinitesimal transformations of Lorentz one has

$$\delta\psi = \frac{i}{2} \omega_{\mu\nu} \Sigma^{\mu\nu} \psi, \quad \delta\psi^T = \frac{i}{2} \omega_{\mu\nu} \psi^T \Sigma^{\mu\nu T} = -\frac{i}{2} \omega_{\mu\nu} \psi^T \mathcal{C}^{-1} \Sigma^{\mu\nu} \mathcal{C}\tag{242}$$

where the latter expression emerges by considering the properties (222) of the charge conjugation matrix, i.e.  $\gamma^{\mu T} = -\mathcal{C}^{-1} \gamma^\mu \mathcal{C}$ , so that  $\Sigma^{\mu\nu T} = -\mathcal{C}^{-1} \Sigma^{\mu\nu} \mathcal{C}$ . Thus, one finds  $\delta\mathcal{L}_M = 0$ . Note that the Majorana mass term remains nonvanishing for chiral fermions as in terms of chiral components it reads

$$\mathcal{L}_M = \frac{M}{2} \psi^T \mathcal{C}^{-1} \psi + h.c. = \frac{M}{2} (\psi_L^T \mathcal{C}^{-1} \psi_L + \psi_R^T \mathcal{C}^{-1} \psi_R) + h.c.\tag{243}$$

and by setting for example  $\psi_R = 0$  one finds a mass term for  $\psi_L$ .

Finally, let us remember, without going into much details, that a theory of chiral fermions is equivalently described in terms of Majorana fermions  $\mu(x)$ , that is Dirac spinors that satisfy a reality condition of the form  $\mu_c(x) = \mu(x)$ . A Majorana fermion essentially contains a Weyl fermion plus its Dirac conjugate<sup>9</sup>

$$\mu(x) \sim \psi_L(x) + \psi_{L,c}(x).\tag{244}$$

<sup>8</sup> In chiral models where parity is not conserved, there may be several right-handed and left-handed fermions with different charges and even different in numbers. The fermions entering the standard model are in fact chiral, in the sense that left-hand fermions have couplings different from their right-handed partners (i.e. different charges). They cannot have Dirac masses, which would not be gauge invariant: the transformation laws of  $\psi_L$  under the standard model symmetries ( $SU(3) \times SU(2) \times U(1)$ ) are different from those of  $\psi_R$ . The Dirac masses of the standard model emerge as a consequence of the Higgs mechanism for the spontaneous breaking of the  $SU(2) \times U(1)$  gauge symmetry.

<sup>9</sup> The Dirac conjugate of a Weyl spinor has opposite chirality of the original Weyl spinor and is equivalently described by the charge conjugate of the original Weyl spinor,  $\psi_{L,c} = \overline{\mathcal{C}\psi_L}^T$ , see eq. (226).



To verify that the charge conjugation of a left handed fermion is right handed, one computes

$$\psi_{L,c} = \mathcal{C}\overline{\psi_L}^T = \mathcal{C}(\overline{\psi_L}P_R)^T = \mathcal{C}P_R\overline{\psi_L}^T = P_R\mathcal{C}\overline{\psi_L}^T = P_R\psi_{L,c}. \quad (245)$$

The Majorana fermion is not irreducible under Lorentz transformations, just like the Dirac fermion.

### Analogies of Dirac and Majorana masses in scalar theories

By definition, a Majorana fermion is described by a spinor field that satisfies a reality condition of the type  $\mu_c(x) = \mu(x)$ , often interpret by saying that particles and antiparticles coincide. It describes an electrically uncharged fermion. Indeed the transformation (230) is no longer a symmetry: it cannot be applied to  $\mu$  as it does not respect the constraint  $\mu_c = \mu$ , and the corresponding conserved charge no longer exists. A Majorana fermion possesses half the degrees of freedom of a Dirac fermion.

One may think of a Majorana fermion as a left-handed Weyl field  $\psi_L$  plus its complex conjugate  $\psi_L^*$  which describes a right-handed field (often one prefers to use the charge conjugate  $\psi_{L,c}$  instead of  $\psi_L^*$ ).

To better understand the physical meaning of Dirac and Majorana mass, it is useful to describe an analogy with scalar particles. The analog of a Majorana fermion is a real scalar field  $\varphi$ , which satisfies  $\varphi^* = \varphi$  and a Klein-Gordon equation with mass  $\mu$ , derivable from the lagrangian

$$\mathcal{L} = -\frac{1}{2}\partial^\mu\varphi\partial_\mu\varphi - \frac{1}{2}\mu^2\varphi\varphi. \quad (246)$$

Two free real scalar fields  $\varphi_1$  and  $\varphi_2$  with different masses  $\mu_1$  and  $\mu_2$ , are described by the lagrangian

$$\mathcal{L} = -\frac{1}{2}\partial^\mu\varphi_1\partial_\mu\varphi_1 - \frac{1}{2}\mu_1^2\varphi_1^2 - \frac{1}{2}\partial^\mu\varphi_2\partial_\mu\varphi_2 - \frac{1}{2}\mu_2^2\varphi_2^2. \quad (247)$$

If the masses are identical,  $\mu_1 = \mu_2 \equiv m$ , the model acquires a  $SO(2)$  symmetry that mixes the fields  $\varphi_1$  and  $\varphi_2$ , and the lagrangian becomes

$$\mathcal{L} = -\frac{1}{2}\partial^\mu\varphi_1\partial_\mu\varphi_1 - \frac{1}{2}\partial^\mu\varphi_2\partial_\mu\varphi_2 - \frac{1}{2}m^2(\varphi_1^2 + \varphi_2^2). \quad (248)$$

The term  $(\varphi_1^2 + \varphi_2^2)$  is  $SO(2)$  invariant, as is the kinetic term.

The lagrangian can be written in terms of a complex field  $\phi$  defined by

$$\phi = \frac{1}{\sqrt{2}}(\varphi_1 + i\varphi_2), \quad \phi^* = \frac{1}{\sqrt{2}}(\varphi_1 - i\varphi_2) \quad (249)$$

with  $\varphi_1$  and  $\varphi_2$  the real and imaginary part of  $\phi$ , respectively. In this basis, the lagrangian (248) takes the form

$$\mathcal{L} = -\partial^\mu\phi^*\partial_\mu\phi - m^2\phi^*\phi. \quad (250)$$

The symmetry  $SO(2) \equiv U(1)$  becomes  $\phi' = e^{i\alpha}\phi$  and  $\phi'^* = e^{-i\alpha}\phi^*$ , and the corresponding charge is often called ‘‘bosonic number’’ (it acts as the electric charge in a coupling to electromagnetism).

Now the point is: (i) a complex field  $\phi^*$  is analogous to a Dirac fermion, and its mass  $m$  is analogous to the mass of Dirac; (ii) a real field  $\varphi$  is analogous to a Majorana fermion, and its mass  $\mu$  is analogous to the Majorana mass.

Two Majorana fields with identical masses form a Dirac fermion, with their identical masses becoming the Dirac mass. A key property of the latter is that it respects the  $U(1)$  invariance. We also understand that, by breaking the  $U(1)$  invariance, it is possible to introduce a further mass term for  $\phi$  and  $\phi^*$ , directly visible in the  $\varphi_1$  and  $\varphi_2$  basis, recall eq. (247). It can be written in the  $\phi$  and  $\phi^*$  basis as

$$\mathcal{L} = -\partial^\mu \phi^* \partial_\mu \phi - m^2 \phi^* \phi - \frac{M^2}{2} (\phi \phi + \phi^* \phi^*) . \quad (251)$$

The term with  $M^2$  is the analog of a Majorana mass term for a Dirac fermion: it is a mass term that breaks the  $U(1)$  invariance, but keeps the lagrangian real. The explicit relationships between the mass terms are given by

$$\begin{aligned} \mu_1^2 &= m^2 + M^2 \\ \mu_2^2 &= m^2 - M^2 . \end{aligned}$$

Note that  $M^2$  does not have to be positive, while  $\mu_1^2$  and  $\mu_2^2$  must be positive to have a potential energy limited from below. The physical masses are  $\mu_1$  and  $\mu_2$ , as they give the location of the poles in the propagators (they are the eigenvalues of the mass matrix). In this analogy, we can reinterpret eq. (249) as saying that  $\phi$  is the analog of a Weyl fermion and  $\phi^*$  of its conjugate complex, remembering however that for the bosons there is no invariant concept of chirality.

### Green functions and propagator

Let us briefly introduce also the Green function, and related boundary conditions, for the Dirac equation. The Green function satisfies the equation

$$(\not{\partial}_x + m)S(x - y) = \delta^{(4)}(x - y) , \quad (252)$$

formally solved in Fourier transform by

$$S(x - y) = \int \frac{d^4 p}{(2\pi)^4} e^{ip \cdot (x-y)} \frac{-i\not{p} + m}{p^2 + m^2} . \quad (253)$$

Appropriate boundary conditions can be implemented by the prescription how to integrate around the poles (points in momentum space where  $p^2 + m^2$  vanishes). Exactly the same discussion given for the Klein-Gordon equation applies to the present context. In particular, the propagator is obtained by using the Feynman  $i\epsilon$  prescription, and takes the form

$$S(x - y) = \int \frac{d^4 p}{(2\pi)^4} e^{ip \cdot (x-y)} \frac{-i\not{p} + m}{p^2 + m^2 - i\epsilon} \quad (254)$$

The prescription  $\epsilon \rightarrow 0^+$  makes it consistent to interpret the quantum fluctuations as corresponding to particles or antiparticles with positive energies that propagate from the past to the future, just as in the case of scalar particles. In QFT it emerges as the correlation function

$$\langle \psi(x) \bar{\psi}(y) \rangle = -iS(x - y)$$

which propagates a particle from  $y$  to  $x$  if  $x^0 > y^0$ , and an antiparticle from  $x$  to  $y$  if  $y^0 > x^0$ .

## 5 Particles of spin $s \geq 1$

At this point it is relatively easy to describe relativistic wave equations for particles of spin  $s \geq 1$  with non-vanishing mass, modeling them on the Klein-Gordon equation (for bosonic fields of integer spin) and Dirac equation (for fermionic fields of semi-integer spin). They are known as Fierz-Pauli equations. The difficulties lie in the introduction of interactions, a non-trivial and subtle problem that we are not going to discuss in these notes.

In the massive case of integer spin  $s$  (i.e.  $s = 0, 1, 2, \dots$  is an integer) the wave function is given by a completely symmetric tensor of rank  $s$ , i.e. with  $s$  vector indices  $\phi_{\mu_1 \dots \mu_s}$ , which satisfies the KG equation in addition to constraint that impose transversality and a condition of vanishing trace

$$\begin{aligned} (\square - m^2)\phi_{\mu_1 \dots \mu_s} &= 0 \\ \partial^\mu \phi_{\mu \mu_2 \dots \mu_s} &= 0 \\ \phi^\mu_{\mu \mu_3 \dots \mu_s} &= 0. \end{aligned} \quad (255)$$

To understand their meaning, it is useful to study plane wave solutions, identified by an ansatz of the form

$$\phi_{\mu_1 \dots \mu_s}(x) \sim \epsilon_{\mu_1 \dots \mu_s}(p) e^{ip_\mu x^\mu}. \quad (256)$$

where the polarization tensor  $\epsilon_{\mu_1 \dots \mu_s}(p)$  describes covariantly the spin orientation.

The first equation imposes the correct relativistic relation between energy and momentum on the plane wave solution for massive particle:  $p^2 + m^2 = 0$ . The second equation (the transversality condition) eliminates in a covariant way non-physical degrees of freedom: choosing the frame of reference at rest with the particle, one may recognize that the independent components of the wave function must have only spatial indices. The latter describe the possible orientations in space of the spin (polarizations)

$$m \epsilon_{0\mu_2 \dots \mu_s}(p) = 0 \quad \rightarrow \quad \text{only } \epsilon_{i_1 \dots i_s}(p) \neq 0 \quad (257)$$

where we have split the index  $\mu = (0, i)$  into time and space components. The third equation (the vanishing trace condition) reduces the components of the polarization tensor to have only those components corresponding to the irreducible representation of spin  $s$ , which as known from quantum mechanics form a tensor of rank  $s$  (i.e. with  $s$  indices) of  $SO(3)$  that must be completely symmetric and traceless: it has then precisely  $2s + 1$  independent components corresponding to the  $2s + 1$  possible spin orientations.

Let us verify the number of polarizations by counting the number of independent components of a fully symmetric tensor with  $s$  indices taking only three values (the spatial directions of the frame at rest with the particle) and then subtracting the components associated to the trace of the tensor (to be eliminated to get a vanishing trace<sup>10</sup>)

$$\frac{3 \cdot 4 \cdot \dots \cdot (3 + s - 1)}{s!} - \frac{3 \cdot 4 \cdot \dots \cdot (3 + s - 3)}{(s - 2)!} = \frac{1}{2}(s + 2)(s + 1) - \frac{1}{2}s(s - 1) = 2s + 1. \quad (258)$$

This number is correct, and supports the statement that the wave field  $\phi_{\mu_1 \dots \mu_s}(x)$  corresponds to massive quanta of spin  $s$ . The calculation is valid for  $s \geq 2$ , but easily extended to lower  $s$ .

<sup>10</sup> A trace can be taken on any two indices, but by symmetry it is equivalent in taking the trace on the first 2 indices: the remaining tensor has  $s - 2$  totally symmetric indices.

In the case of a massive particle of half-integer spin  $s = n + \frac{1}{2}$  (where  $n$  is an integer), the field is a spinor with in addition  $n$  symmetrical vector indices  $\psi_{\mu_1 \dots \mu_n}$  (the spinor index is understood), and satisfies a Dirac equation with additional constraints that impose transversality and gamma-tracelessness

$$\begin{aligned} (\gamma^\mu \partial_\mu + m) \psi_{\mu_1 \dots \mu_n} &= 0 \\ \partial^\mu \psi_{\mu \mu_2 \dots \mu_n} &= 0 \\ \gamma^\mu \psi_{\mu \mu_2 \dots \mu_n} &= 0 . \end{aligned} \tag{259}$$

We will not discuss any further these equations.

In the limit of vanishing mass, the correct field equations must have only two physical polarizations<sup>11</sup> (the two possible helicities  $h = \pm s$ ). This is usually obtained by considering equations with gauge symmetries. They need a more detailed discussion, and will not be presented in these notes, except for the case  $s = 1, 2$ . *Gauge symmetries* are responsible for reducing the number of degrees of freedom (i.e. the number of components of the wave function that satisfies the equations of motion) from  $2s + 1$ , needed for a massive particle of spin  $s$ , to the 2 components needed for massless particles.

As said, we will briefly review the case of massless spin 1, which certainly admits non-trivial interactions with fields of spin 0, 1/2 and 1, as used in the construction of the Standard Model, and briefly mention the case of massless spin 2 (the graviton, the quantum of the gravitational waves). This is done by reviewing first the massive case, so to better understand differences and similarities. Massless higher spin particles do not seem to admit non-trivial interactions, and they did not find phenomenological applications thus far.

### Massive spin 1 particle: Proca equations

Massive particles of spin 1 are described by (255) with  $s = 1$ . It is customary to denote the wave function  $\phi_\mu(x)$  by  $A_\mu(x)$ , so that the equations reads

$$\begin{aligned} (\square - m^2) A_\mu &= 0 \\ \partial^\mu A_\mu &= 0 . \end{aligned} \tag{260}$$

For this specific case they are known as Proca equations. They can be derived from an action, which takes the form

$$S_P[A_\mu] = \int d^4x \left( -\frac{1}{4} F_{\mu\nu} F^{\mu\nu} - \frac{1}{2} m^2 A_\mu A^\mu \right) \tag{261}$$

where

$$F_{\mu\nu} = \partial_\mu A_\nu - \partial_\nu A_\mu . \tag{262}$$

An integration by parts brings the action in an alternative form

$$S_P[A_\mu] = \int d^4x \left( -\frac{1}{2} \partial_\nu A_\mu \partial^\nu A^\mu + \frac{1}{2} (\partial_\mu A^\mu)^2 - \frac{1}{2} m^2 \right) \tag{263}$$

which is similar to the action of four Klein-Gordon fields  $A_\mu$  (given by the first and third terms), but with the crucial addition of the second term  $(\partial_\mu A^\mu)^2$  with a very precise coefficient. The

---

<sup>11</sup>Recall that one cannot find a frame at rest with the particle, as the particle necessarily travels at the speed of light in all reference frames, and so the counting above must be modified

latter will be responsible for the constraint that reduces the number of degrees of freedom from 4 to 3. By varying  $A_\mu$  one finds the equations of motion

$$\frac{\delta S_P[A]}{\delta A^\nu(x)} \equiv \partial^\mu F_{\mu\nu}(x) - m^2 A_\nu(x) = 0 \quad (264)$$

also called Proca equations. They are equivalent to the ones above. In fact, one notices that the identity  $\partial^\mu \partial^\nu F_{\mu\nu} = 0$  implies

$$\partial^\mu \partial^\nu F_{\mu\nu} = m^2 \partial^\nu A_\nu = 0 . \quad (265)$$

Thus for  $m \neq 0$  one has a constraint

$$\partial^\mu A_\mu = 0 . \quad (266)$$

Using this relationship, one rewrites Proca equations in (264) as four Klein-Gordon equations plus a constraint, as in eq. (260). The constraint tells that only three of the four component of  $A_\mu$  are independent, and the equations covariantly describe the three polarizations expected for a particle of spin 1.

The invariance of the action and of the equations of motion under Lorentz transformations is obvious, with  $A_\mu$  transforming in the vectorial representation as indicated by its index position

$$\begin{aligned} x^\mu &\longrightarrow x^{\mu'} = \Lambda^\mu{}_{\nu'} x^\nu \\ A_\mu(x) &\longrightarrow A_{\mu'}(x') = \Lambda_\mu{}^{\nu'} A_\nu(x) . \end{aligned} \quad (267)$$

### Plane wave solutions

Plane wave solutions of the Proca equation are obtained inserting in (260) the ansatz

$$A_\mu = \varepsilon_\mu(p) e^{ip \cdot x} \quad (268)$$

to find that: (i) the momentum  $p_\mu$  must satisfy the “mass shell” condition  $p_\mu p^\mu = -m^2$  (first equation in (260)), (ii) a linear combination of the four independent polarizations must vanish,  $p^\mu \varepsilon_\mu(p) = 0$  (second equation in (260)). The three remaining polarizations describe the three degrees of freedom of a spin 1 particle in a manifestly covariant manner. In the rest frame, the polarization is given by a vector in three-dimensional space (spin 1). Real solutions can be obtained by combining with appropriate Fourier coefficients these physical plane waves. The associated quanta have mass  $m$  and spin 1, and antiparticles (corresponding to solutions with negative energies) coincide with the particles (there is no charge that differentiates particles and antiparticles). If one considers a complex Proca field, particles and antiparticles are different: they have opposite charges under a  $U(1)$  symmetry, which may be interpreted as the electric charge, and used to describe the  $W^\pm$  particles of the Standard Model.

### Green function and propagator

With an integration by part one can rewrite the action (261) in the form

$$S_P[A_\mu] = -\frac{1}{2} \int d^4x A_\mu(x) K^{\mu\nu}(\partial) A_\nu(x) \quad (269)$$

to identify the differential operator  $K^{\mu\nu}(\partial) = (-\square + m^2)\eta^{\mu\nu} + \partial^\mu \partial^\nu$ . Using this notation the Proca field equations read

$$K^{\mu\nu}(\partial) A_\nu(x) = 0 . \quad (270)$$

The relative Green function  $G_{\mu\nu}(x-y)$  by definition satisfies

$$K^{\mu\nu}(\partial_x)G_{\nu\lambda}(x-y) = \delta_\lambda^\mu \delta^4(x-y) . \quad (271)$$

It is identified in Fourier space by

$$G_{\mu\nu}(x-y) = \int \frac{d^4p}{(2\pi)^4} e^{ip \cdot (x-y)} \underbrace{\left( \frac{\eta_{\mu\nu} + \frac{p_\mu p_\nu}{m^2}}{p^2 + m^2} \right)}_{\tilde{G}_{\mu\nu}(p)} . \quad (272)$$

Indeed, by symmetry the  $\tilde{G}_{\mu\nu}(p)$  of eq. (272) must have the form

$$\tilde{G}_{\mu\nu}(p) = A(p)\eta_{\mu\nu} + B(p)p_\mu p_\nu \quad (273)$$

and requiring (271) one finds

$$A(p) = \frac{1}{p^2 + m^2} , \quad B(p) = \frac{1}{m^2} A(p) . \quad (274)$$

Quantizing the Proca field with second quantized methods one finds that the Green function is proportional to the propagator

$$\langle A_\mu(x)A_\nu(y) \rangle = -iG_{\mu\nu}(x-y) = -i \int \frac{d^4p}{(2\pi)^4} e^{ip \cdot (x-y)} \underbrace{\left( \frac{\eta_{\mu\nu} + \frac{p_\mu p_\nu}{m^2}}{p^2 + m^2 - i\epsilon} \right)}_{\tilde{G}_{\mu\nu}(p)} \quad (275)$$

where  $\epsilon \rightarrow 0^+$ . It describes as usual the propagation of particles and antiparticles of spin 1. Note that the propagator is singular in the limit of vanishing mass,  $m \rightarrow 0$ . Massless spin 1 particles require a separate treatment.

### Massless spin 1 particle: Maxwell equations

For  $m \rightarrow 0$ , the Proca action reduces to the Maxwell action

$$S_{Max}[A_\mu] = \int d^4x \left( -\frac{1}{4} F_{\mu\nu} F^{\mu\nu} \right) \quad (276)$$

that correctly describes the relativistic waves associated to massless particles of spin 1 (i.e. of helicity  $h = \pm 1$ ). They correspond to half of the Maxwell equations in vacuum

$$\partial^\mu F_{\mu\nu} = 0 . \quad (277)$$

Using the definition of  $F_{\mu\nu}$  they can be written as

$$\partial^\mu F_{\mu\nu} = \partial^\mu (\partial_\mu A_\nu - \partial_\nu A_\mu) = \square A_\nu - \partial_\nu \partial^\mu A_\mu = 0 . \quad (278)$$

The other half of the Maxwell equations are automatically solved by having expressed  $F_{\mu\nu}$  in terms of the gauge potential  $A_\mu$ , i.e.

$$F_{\mu\nu} = \partial_\mu A_\nu - \partial_\nu A_\mu . \quad (279)$$

Then,  $F_{\mu\nu}$  satisfies the Bianchi identities

$$\partial_\lambda F_{\mu\nu} + \partial_\mu F_{\nu\lambda} + \partial_\nu F_{\lambda\mu} = 0 \quad (280)$$

as substituting (279) into (280) one finds that all terms cancel two by two. These Bianchi identities constitute the remaining Maxwell equations. They can be written in an equivalent way using the fully antisymmetric tensor  $\epsilon^{\mu\nu\lambda\rho}$  (normalized by  $\epsilon^{0123} = 1$ )

$$\epsilon^{\mu\nu\lambda\rho} \partial_\nu F_{\lambda\rho} = 0 \quad (281)$$

which in terms of  $A_\mu$  become  $\epsilon^{\mu\nu\lambda\rho} \partial_\nu \partial_\lambda A_\rho = 0$ , an obvious identity for any  $A_\rho$ . It is also customary to define the dual field strength  $\tilde{F}_{\mu\nu}$  by

$$\tilde{F}_{\mu\nu} = \frac{1}{2} \epsilon_{\mu\nu\lambda\rho} F^{\lambda\rho} \quad (282)$$

with  $\epsilon_{0123} = -1$ , which gives a field strength with electric and magnetic fields interchanged by  $\vec{E} \rightarrow \vec{B}$  and  $\vec{B} \rightarrow -\vec{E}$ . Then, the second set of Maxwell equations can be written as

$$\partial^\mu \tilde{F}_{\mu\nu} = 0. \quad (283)$$

The novelty of this formulation of massless spin 1 particles is the presence of a *gauge symmetry*

$$A_\mu(x) \rightarrow A'_\mu(x) = A_\mu(x) + \partial_\mu \alpha(x) \quad (284)$$

which leaves the action (276) unchanged. Indeed  $F_{\mu\nu}$  is invariant, and the full action remains invariant. As we shall see, this fact implies that the action describes only two degrees of freedom instead of three: they correspond to the maximum and minimum spin states when projected along the direction of motion (helicity  $h = \pm 1$ ). The infinitesimal gauge transformation has the same form

$$\delta A_\mu(x) = \partial_\mu \alpha(x) \quad (285)$$

with  $\alpha(x)$  considered now an infinitesimal arbitrary function. We can think of this local symmetry as associated with the  $U(1)$  group, as one can write (284) in the form

$$A_\mu(x) \rightarrow A'_\mu(x) = A_\mu(x) - ie^{-i\alpha(x)} \partial_\mu e^{i\alpha(x)} \quad (286)$$

where  $e^{i\alpha(x)} \in U(1)$  for any spacetime point.

### Plane wave solution

The equations of motion do not have a unique solution (even fixing initial conditions) because of the gauge symmetry: there is a combination of the dynamical variables that does not have a unique evolution, as its temporal development can be changed arbitrarily with a gauge transformation. However, keeping this gauge redundancy is very useful to have Lorentz invariance manifest, which is instrumental for introducing interactions in a consistent way with relativistic invariance. The Standard Model is indeed a gauge theory with local symmetry group  $SU(3) \times SU(2) \times U(1)$ .

Gauge invariance can be used to set auxiliary conditions (gauge-fixing conditions) that allow to find physical solutions by eliminating (sometimes only partially) equivalent configurations

generated by the gauge symmetry. We choose to partially fix the gauge by imposing a covariant constraint (the Lorenz gauge)

$$\partial^\mu A_\mu = 0 \quad (287)$$

One may verify that this constraint can always be imposed. This condition does not fix the gauge symmetry completely, but some residual gauge transformations are left over, namely those with local parameter  $\alpha(x)$  that satisfies  $\square\alpha(x) = 0$ . In the Lorenz gauge the equations of motion simplify to

$$\square A_\mu = 0, \quad (288)$$

the plane wave solutions are

$$A_\mu(x) = \varepsilon_\mu(p)e^{ip \cdot x}, \quad p_\mu p^\mu = 0, \quad p_\mu \varepsilon^\mu(p) = 0 \quad (289)$$

and contain 3 independent polarizations  $\varepsilon^\mu(p)$ , as one is removed by the the Lorenz gauge constraint  $p_\mu \varepsilon^\mu(p) = 0$ . Of these three remaining polarizations, the longitudinal one (i.e. the one with  $\varepsilon_\mu(p) = p_\mu$ ) can be removed by using *residual gauge transformations*, i.e. gauge transformations that leave the Lorenz condition (287) unchanged. They are gauge transformations of the form  $\delta A_\mu(x) = \partial_\mu \alpha(x)$ , with  $\alpha(x)$  such that the Lorenz gauge (287) is not modified. As anticipated, may check that these residual gauge transformations must satisfy

$$\square \alpha = 0. \quad (290)$$

A plane wave solution for the gauge function  $\alpha(x) = ie^{ip \cdot x}$  with  $p_\mu p^\mu = 0$ , identifies a non-physical solution of the form

$$A_\mu(x) = \partial_\mu \alpha(x) = -p_\mu e^{ip \cdot x} \quad (291)$$

where the polarization is proportional to  $p_\mu$ . Evidently this solution is equivalent to  $A_\mu = 0$ . Therefore, a plane wave with longitudinal polarization  $\varepsilon_\mu(p) = p_\mu$  is removable by a residual gauge transformation as

$$A'_\mu(x) = p_\mu e^{ip \cdot x} + \partial_\mu \alpha(x) = 0. \quad (292)$$

We conclude that only two independent physical polarizations remain, which can be shown to correspond to the two possible helicities of the photon.

### Spin 2 massive particle: Pauli-Fierz equations

The general treatment of spin  $s$  is here specialized to the case of  $s = 2$ . The dynamical variables are grouped into a symmetric tensor of rank two,  $\phi_{\mu\nu}(x)$ , which satisfies eq.

$$\begin{aligned} (\square - m^2)\phi_{\mu\nu} &= 0 \\ \partial^\mu \phi_{\mu\nu} &= 0 \\ \phi^\mu{}_\mu &= 0 \end{aligned} \quad (293)$$

with plane wave solutions that carry 5 independent polarizations, corresponding precisely to the polarization of a particle of spin 2.

### Spin 2 massless particle: linearized Einstein equations

The previous equations are not sufficient to describe the massless case, as only 2 physical polarizations are expected. They correspond to the maximum and minimum possible helicities



of the particle,  $h = \pm 2$ . Gauge symmetries are needed in a Lorentz covariant description, and they are used to eliminate the non-physical polarizations, just as seen for spin 1. We indicate the spin 2 field with the symmetric tensor  $h_{\mu\nu}(x)$ , that in Einstein's theory of gravitation corresponds to the deformation of the Minkowski metric  $\eta_{\mu\nu}$  to a curved metric  $g_{\mu\nu}(x) = \eta_{\mu\nu} + h_{\mu\nu}(x)$ .

Using the notation

$$h = h^\mu{}_\mu \quad (294)$$

the gauge invariant equations are given by

$$\square h_{\mu\nu} - \partial_\mu \partial^\sigma h_{\sigma\nu} - \partial_\nu \partial^\sigma h_{\sigma\mu} + \partial_\mu \partial_\nu h = 0. \quad (295)$$

They are invariant under the local symmetries

$$\delta h_{\mu\nu} = \partial_\mu \xi_\nu + \partial_\nu \xi_\mu \quad (296)$$

where  $\xi_\mu(x)$  are four arbitrary spacetime functions (they form a vector field).

Gauge symmetry is verified by a direct calculation: varying eq. (295) under (296) produces a vanishing result

$$\square(\partial_\mu \xi_\nu + \partial_\nu \xi_\mu) - \partial_\mu(\square \xi_\nu + \partial_\nu \partial \cdot \xi) - \partial_\nu(\square \xi_\mu + \partial_\mu \partial \cdot \xi) + \partial_\mu \partial_\nu 2 \partial \cdot \xi = 0. \quad (297)$$

Let us now study the plane wave solutions to check that there are indeed only 2 inequivalent polarizations. We use the four gauge symmetries to impose four gauge conditions (known as the de Donder gauge)

$$\partial^\mu h_{\mu\nu} = \frac{1}{2} \partial_\nu h \quad (298)$$

and the equations (295) simplify to

$$\square h_{\mu\nu} = 0. \quad (299)$$

In analogy with the massless spin 1 case, we have residual gauge transformations with local parameters  $\xi_\mu(x)$  satisfying

$$\square \xi_\mu = 0 \quad (300)$$

so that the truly physical solutions, which cannot be eliminated by means of gauge transformations, are 2. In fact, we calculate 10 (independent components of  $h_{\mu\nu}$ )  $-$  4 (number of constraints in de Donder gauge)  $-$  4 (number of solutions that can be eliminated with residual gauge transformations)  $=$  2. With a more refined analysis, one can prove that these two independent polarizations correspond to the two physical helicities of the gravitational waves  $h = \pm 2$ .

Finally, let us mention that these equations emerge from the linearization of the Einstein equations in vacuum

$$R_{\mu\nu}(g) = 0 \quad (301)$$

where  $R_{\mu\nu}(g)$  is the Ricci tensor built for metric  $g_{\mu\nu}(x) = \eta_{\mu\nu} + h_{\mu\nu}(x)$ . In the linearization one keeps only terms linear in  $h_{\mu\nu}(x)$ . Gauge symmetry is related to the invariance under an arbitrary change of coordinates, suitably linearized.

## A Action principle

We review the least action principle, tracing its application in mechanics and field theories.

Consider a non-relativistic particle of mass  $m$  that moves in a single dimension with coordinate  $q$ , subject to a conservative force  $F = -\frac{\partial}{\partial q}V(q)$ . Newton's equation of motion reads

$$F = m\ddot{q} . \quad (302)$$

It can be derived from an action principle. The action is a functional of the trajectory of the particle  $q(t)$  (the dynamical variable of the system) and associates a real number to each function  $q(t)$ . The simplest physical systems are described by an action of the type

$$S[q] = \int_{t_i}^{t_f} dt L(q, \dot{q}) , \quad L(q, \dot{q}) = \frac{m}{2}\dot{q}^2 - V(q) \quad (303)$$

where  $L(q, \dot{q})$  is the lagrangian. The principle of least action establishes that: *the classic trajectory that joins two points of configuration space is the one that minimizes the action  $S$ .*

To demonstrate this statement we study the condition for having a minimum of the action. We first assume suitable boundary conditions by fixing the value of  $q(t)$  at initial and final times:  $q(t_i) = q_i$  and  $q(t_f) = q_f$ . Then, varying the function  $q(t)$  to a new one  $q(t) + \delta q(t)$ , where  $\delta q(t)$  is an arbitrary infinitesimal variation (with  $\delta q(t_i) = \delta q(t_f) = 0$  to leave the boundary conditions unchanged), and imposing that the action is minimized by the original trajectory  $q(t)$  one finds

$$\begin{aligned} 0 &= \delta S[q] = S[q + \delta q] - S[q] \\ &= \int_{t_i}^{t_f} dt \left[ m\dot{q}\delta\dot{q} - \frac{\partial V(q)}{\partial q}\delta q \right] = m\dot{q}\delta q \Big|_{t_i}^{t_f} - \int_{t_i}^{t_f} dt \left[ m\ddot{q} + \frac{\partial V(q)}{\partial q} \right] \delta q \\ &= - \int_{t_i}^{t_f} dt \left[ m\ddot{q} + \frac{\partial V(q)}{\partial q} \right] \delta q . \end{aligned}$$

Since the variations  $\delta q(t)$  are arbitrary functions, the minimum is reached when the function  $q(t)$  satisfies the classical equations of motion

$$m\ddot{q} + \frac{\partial V(q)}{\partial q} = 0 . \quad (304)$$

This reproduces Newton's equation (302). In general, one obtains the Euler-Lagrange equations

$$\begin{aligned} 0 &= \delta S[q] = \delta \int_{t_i}^{t_f} dt L(q, \dot{q}) = \int_{t_i}^{t_f} dt \left[ \frac{\partial L(q, \dot{q})}{\partial \dot{q}} \delta \dot{q} + \frac{\partial L(q, \dot{q})}{\partial q} \delta q \right] \\ &= \frac{\partial L(q, \dot{q})}{\partial \dot{q}} \delta q \Big|_{t_i}^{t_f} - \int_{t_i}^{t_f} dt \left[ \frac{d}{dt} \frac{\partial L(q, \dot{q})}{\partial \dot{q}} - \frac{\partial L(q, \dot{q})}{\partial q} \right] \delta q \\ &= - \int_{t_i}^{t_f} dt \left[ \frac{d}{dt} \frac{\partial L(q, \dot{q})}{\partial \dot{q}} - \frac{\partial L(q, \dot{q})}{\partial q} \right] \delta q \end{aligned}$$

so that

$$\frac{d}{dt} \frac{\partial L(q, \dot{q})}{\partial \dot{q}} - \frac{\partial L(q, \dot{q})}{\partial q} = 0 . \quad (305)$$

Observations:

1. The action has dimension  $[S] = [\hbar] = [\text{energy} \times \text{time}] = ML^2/T$ .
2. The lagrangian equations of motion are often of second order in time. Thus, one expects two “initial conditions” (or, more generally, boundary conditions), conveniently chosen by fixing the position at the initial and final times.
3. The equations of motion are expressible as the functional derivative of the action

$$\frac{\delta S[q]}{\delta q(t)} = 0 \quad (306)$$

with the functional derivative defined implicitly by the variation  $\delta S[q] = \int dt \frac{\delta S[q]}{\delta q(t)} \delta q(t)$ . Note that  $\frac{\delta q(t)}{\delta q(t')} = \delta(t - t')$ .

4. The equations of motion do not change if one adds a total derivative to the lagrangian  $L$ ,  $L \rightarrow L' = L + \frac{d}{dt}\Lambda$ .
5. The lagrangian formalism extends easily to systems with more than one degrees of freedom, and with a little more attention to field theories (systems with an infinite number of degrees of freedom).

To appreciate this last point, let us consider a set of dynamical fields  $\phi_i(x) = \phi_i(t, \vec{x})$ , where  $x$  indicates the spacetime point. By dynamics one means the evolution along time  $t$ . For fixed  $t$  the dynamical fields  $\phi_i(t, \vec{x})$  are indexed by  $i$  (which labels a discrete set of fields) and  $\vec{x} \in R^3$ , that tells us that at every point in space there is a dynamical variable: thus there are an infinite number of degrees of freedom. By discretizing the space and considering a finite volume, one can approximate a field theory by a mechanical model with a finite number of degrees of freedom. Typically, when the latter are the true physical degrees of freedom (e.g. in the atomic structure of matter) but large in number, the continuum approximation is very useful. The lagrangian  $L$  is often expressed as an integral of a lagrangian density  $\mathcal{L}$

$$L(t) = \int d^3x \mathcal{L}(\phi_i, \partial_\mu \phi_i) \quad (307)$$

so that the action takes the form

$$S[\phi] = \int dt L(t) = \int d^4x \mathcal{L}(\phi_i, \partial_\mu \phi_i) . \quad (308)$$

Imposing the extremality condition  $\delta S = 0$ , one finds the corresponding Euler-Lagrange equations

$$\partial_\mu \frac{\partial \mathcal{L}}{\partial(\partial_\mu \phi_i)} - \frac{\partial \mathcal{L}}{\partial \phi_i} = 0 . \quad (309)$$

### Symmetries and Noether's theorem

The study of the symmetries of a physical system is useful for identifying the equations of motion governing the system and for solving them. We define the concept of *symmetry* by:

*A symmetry is a transformation of the dynamical variables  $q(t)$ , accompanied by a possible transformation of the time  $t$ ,*

$$\begin{aligned} t &\longrightarrow t' = f(t) \\ q(t) &\longrightarrow q'(t') = F(q(t), t) \end{aligned} \quad (310)$$

that leaves the equations of motion invariant in form.

Since the equations of motion are invariant in form, they admit the same solutions and one cannot determine if the motion takes place in the “old frame of reference” or the “new frame of reference”. These reference frames are to be treated on the same footing, without anyone of them being identified as privileged.

A check to test if a transformation is a symmetry makes use of the action. If the action is invariant under the transformation (310), up to boundary terms (which emerge as integrals of total derivatives and do not modify the equations of motion, as recalled in point 4 above)

$$S[q'] = S[q] + \text{boundary terms} \quad (311)$$

then the transformation is a symmetry: the equations obtained from the least action principle must be of the same form, being obtainable from identical actions.

A physical system can present different types of symmetry: discrete symmetries, continuous symmetries (associated with a Lie group), local symmetries (called also gauge symmetries). An even more general concept is that of “background symmetry”, described by generalized transformations that modify also the parameters of the theory (e.g. the coupling constants or those contained in external potentials). They are not true symmetries in the technical sense defined above, but relate solutions of a given theory with certain parameters to the solutions of another theory with different parameters.

For Lie symmetries, symmetries that depend continuously on some parameters, one can prove Noether’s theorem. It states that:

*For each continuous parameter of the symmetry group there exists a conserved charge.*

A proof is the following one. A transformation of symmetry which depends on a parameter  $\alpha$  can be parametrized in a general way as

$$\begin{aligned} t &\longrightarrow t' = f(t, \alpha) \\ q(t) &\longrightarrow q'(t') = F(q(t), t, \alpha) \end{aligned} \quad (312)$$

where by definition the identity transformation is achieved for  $\alpha = 0$ . Infinitesimal transformations (with parameter  $\alpha \ll 1$ ) they can be written as

$$\delta_\alpha q(t) \equiv q'(t) - q(t) = \alpha G(q(t), t) \quad (313)$$

with an appropriate function  $G$  obtainable from the  $F$  and  $f$  in (312). To prove that there is a conserved quantity associated with the symmetry, we extend the symmetry transformation to a more general transformation with parameter  $\alpha(t)$ , no longer constant but depending arbitrarily on the time  $t$  (i.e. an arbitrary function of time)

$$\delta_{\alpha(t)} q(t) = \alpha(t) G(q(t), t) . \quad (314)$$

Generically, this transformation will not be a symmetry, but one can certainly state that the action transforms as

$$\delta_{\alpha(t)} S[q] = \int dt \dot{\alpha}(t) Q(q(t), t) \quad (315)$$

up to boundary terms (integrals of total derivatives). In fact, if we take the case of  $\alpha$  constant the action must be invariant by hypothesis (as we have a symmetry). So, for an arbitrary function  $\alpha(t)$ , the variation cannot depend directly on  $\alpha$ , but only on its derivatives. Now

the quantity  $Q$  that appears in (315) is conserved. To show that, one uses the equations of motion in the form of the “least action principle”, which make the variation vanish for any transformation and in particular for the transformations with local parameter in (314)

$$0 = \delta_{\alpha(t)} S[q] \Big|_{q_0} = \int dt \dot{\alpha}(t) Q \Big|_{q_0} = - \int dt \alpha(t) \dot{Q} \Big|_{q_0} \implies \dot{Q}(q_0(t), t) = 0$$

where we have integrated by parts and used the arbitrariness of the function  $\alpha(t)$  to deduce conservation. Note that we must evaluate the variation of the action at the point of minimum, indicated by  $q_0$ , which solves the Euler-Lagrange equations. The conserved charge  $Q$  is evaluated on the solution of the equations of motion and is conserved. This type of Lie symmetries are called *rigid symmetries* or *global symmetries*. To each parameter of the Lie group there is an associated conserved charge  $Q$ .

Those types of Lie symmetries where the parameter is an arbitrary function of time are called *local symmetries* or *gauge symmetries*. The previous method does not produce any non-trivial conserved quantity, because the variation of the action is always zero, for any local parameter and without using the equations of motion. Local symmetries tell us that the dynamical variables are redundant: with a gauge transformation one can modify arbitrarily the time evolution of certain combinations of the dynamical variables, combinations whose evolution is evidently not fixed by the equations of motion.

The study of symmetries of a physical system is very useful for identifying the correct equations of motion that govern the system. One can define symmetry as follows:  
*A symmetry is a transformation of the dynamical variables  $\phi(x)$ , induced possibly by a transformation of the coordinates  $x^\mu$ ,*

$$\begin{aligned} x'^\mu &\longrightarrow x'^\mu = f^\mu(x) \\ \phi(x) &\longrightarrow \phi'(x') = F(\phi(x), \partial_\mu \phi(x), x, ) \end{aligned} \tag{316}$$

*that leaves the equations of motion invariant in form.*

We talk about internal symmetries (opposite to spacetime symmetries) if the coordinates  $x^\mu$  are not transformed. Since the equations of motion are invariant in form, they admit the same kind of solutions, and one cannot determine if we are in the “old frame of reference” or the “new frame of reference”. These frames of reference are to be treated on equal footing, without any of them being identified as privileged. A test to check if a transformation is a symmetry makes use of the action. If the action is invariant under the transformation (316), up to boundary terms (which emerge as integrals of total derivatives and which do not modify the lagrangian equations of motion, as we know),

$$S[\phi'] = S[\phi] + \text{boundary terms} \tag{317}$$

then the transformation is a symmetry; in fact, the equations deduced from the action principle are of the same form, being obtainable from identical actions.

A physical system can present different types of symmetry: discrete symmetries, continuous symmetries (associated to a Lie group), local symmetries (also called gauge symmetries). An even more general concept is that of “background symmetry”, described by generalized transformations in which the parameters of the theory (often called coupling constants) are transformed as well: for example this is the case if external potentials that might be present

in the action are transformed (thus, a background symmetry is not a true symmetry in the technical sense defined above, but it links solutions of a theory with certain parameters to the solutions of another theory with transformed parameters).

For Lie symmetries, symmetries that depend continuously on some parameters, one can prove the Noether's theorem, which states that:

*For each continuous parameter of the symmetry group of a theory there exists a conserved charge. In field theories, this conservation law is expressed by a continuity equation.*

We demonstrate this theorem for an arbitrary field theory, which includes as a subcase systems with a finite number of degrees of freedom.

A symmetry transformation that depends on a parameter  $\alpha$  can be described in general terms by

$$\begin{aligned} x^\mu &\longrightarrow x'^\mu = f^\mu(x, \alpha) \\ \phi(x) &\longrightarrow \phi'(x') = F(\phi(x), \partial_\mu \phi(x), x, \alpha) \end{aligned} \quad (318)$$

where by definition the identity transformation is given for  $\alpha = 0$ . The infinitesimal transformations (with parameter  $\alpha \ll 1$ ) can be parametrized as follows

$$\delta_\alpha \phi(x) \equiv \phi'(x) - \phi(x) = \alpha G(\phi(x), \partial_\mu \phi(x), x) \quad (319)$$

with an appropriate function  $G$  obtainable from the function  $F$  in (318). By the hypothesis of symmetry, we have that  $\delta_\alpha S[\phi] = 0$ , up to boundary terms that can be dropped. To prove that there is a conserved quantity associated with this symmetry, one extends the symmetry transformation to a more general transformation with parameter  $\alpha(x)$ , no longer constant but depending arbitrarily on the spacetime point

$$\delta_{\alpha(x)} \phi(x) = \alpha(x) G(\phi(x), \partial_\mu \phi(x), x) . \quad (320)$$

This transformation generically will not be a symmetry, and one can certainly state that the action transforms in the following way

$$\delta_{\alpha(x)} S[\phi] = \int d^n x \partial_\mu \alpha(x) J^\mu \quad (321)$$

again up to boundary terms (integrals of total derivatives). In fact, if we take the case of  $\alpha$  constant we must satisfy the hypothesis that the transformation is a symmetry. Then for an arbitrary function  $\alpha(x)$ , the variation depends only on then derivatives of  $\alpha(x)$ , not on  $\alpha(x)$  itself. The current  $J^\mu$  which appears in (321) is the Noether current that satisfies a continuity equation, associated with the conservation of a charge. To see that, one uses the equations of motion, which assure that the variation of the action evaluated on the solutions of the equations of motions must vanish under any transformation (“least action principle”): in particular it must vanish under the transformations with a local parameter given in (320)

$$0 = \delta_{\alpha(x)} S[\phi] \Big|_{\phi_0} = \int d^n x \partial_\mu \alpha(x) J^\mu \Big|_{\phi_0} = - \int d^n x \alpha(x) \partial_\mu J^\mu \Big|_{\phi_0} \implies \partial_\mu J^\mu(\phi_0) = 0 .$$

Here above we have integrated by parts, and used that  $\alpha(x)$  is an arbitrary function, to deduce the continuity equation. Note that we must evaluate the variation of the action at the point of

minimum, indicated with  $\phi_0$ , which solves the equations of motion. Consequently, the current  $J_\mu$  must be evaluated on the solution of the equations of motion (indicated here with the notation  $J^\mu(\phi_0)$ ). This type of Lie symmetries are called *rigid symmetries* or *global symmetries*. For each parameter of the Lie group, there is a conserved charge  $Q$

$$Q = \int d^3x J^0 . \quad (322)$$

This charge is conserved because we can calculate

$$\frac{d}{dt}Q = \int d^3x \partial_0 J^0 = - \int d^3x \partial_i J^i = 0 \quad (323)$$

where it is assumed that the spatial components of the current go to zero quickly enough at infinity to cancel eventual boundary terms (this means that we consider localized solutions in a region of space, and nothing enters or leaves the spatial infinity).

Lie symmetries with parameters that are arbitrary functions of time (and space) are called *local symmetries* or *gauge symmetries*. In this case, the previous method does not produce any Noether current, as the variation of the action is always zero for any local function, without using the equations of motion. The presence of local symmetries tells that the dynamical variables we are using are redundant: with a gauge transformation one can modify arbitrarily the time evolution of a suitable combination of them. Said differently, the evolution of this combination is not fixed by the equations of motion, and can be considered as a redundant variable for the description of the system.

## B Particles with spin

In quantum mechanics the wave function  $\psi(\vec{x})$  is a scalar object. It satisfies the Schrödinger equation and describes a spinless particle. After the discovery of the spin of the electron, Pauli introduced the spin operator  $\vec{S} = \frac{\hbar}{2}\vec{\sigma}$ , defined in terms of the Pauli matrices, which acts on a wave function with two components

$$\psi_m(\vec{x}) = \begin{pmatrix} \psi_{\uparrow}(\vec{x}) \\ \psi_{\downarrow}(\vec{x}) \end{pmatrix}, \quad m = (\uparrow, \downarrow) \quad (324)$$

usually taken to diagonalize  $S^3$ , the third component of the spin. This wave function with two components satisfies a Schrödinger equation, which takes the name of Pauli equation.

One could also consider particles with different spin. In general the spin operator must satisfy the algebra of the angular momentum, the  $SO(3) \sim SU(2)$  Lie algebra,

$$[S^i, S^j] = i\hbar\epsilon^{ijk}S^k, \quad [S^i, \vec{S}^2] = 0 \quad (325)$$

and indeed the Pauli spin operator satisfies such an algebra, with  $\vec{S}^2 = \hbar^2s(s+1) = \frac{3}{4}\hbar^2$ , indeed corresponding to spin  $s = 1/2$ .

Other spins correspond to the irreducible representation of the above algebra, which are labeled by the integer (bosons) or half-integer (fermions) quantum number  $s$ . They contain  $2s + 1$  different components (polarizations). A general spin  $s$  can be obtained also by adding together several spin  $1/2$ , i.e. combining wave functions of different particles of spin  $1/2$ , and keeping the irreducible component of pure spin  $s$ . In any case, having the spin quantum number  $s$  fixed, there are only  $2s + 1$  states, usually written in the basis where  $S^3$  is diagonal as

$$|s, s_3\rangle, \quad s_3 = s, s-1, \dots, -s \quad (326)$$

For integer spin,  $s = 0, 1, 2, \dots$ , one finds the same classification as for the orbital angular momentum ( $l = 0, 1, 2, \dots$ ), and for spin 1 the wave function has just 3 components

$$\psi_m(\vec{x}) = \begin{pmatrix} \psi_{+1}(\vec{x}) \\ \psi_0(\vec{x}) \\ \psi_{-1}(\vec{x}) \end{pmatrix} \sim \begin{pmatrix} \psi_x(\vec{x}) \\ \psi_y(\vec{x}) \\ \psi_z(\vec{x}) \end{pmatrix} = \psi_i(\vec{x}) \quad (327)$$

where  $m = (1, 0, -1)$  and  $i = (x, y, z)$ . The equivalence with the usual vector field  $\psi_i$  is of course obtained by a change of basis (namely,  $\psi_{\pm 1} \sim \psi_x \pm i\psi_y$ ). Thus,  $\psi_i$  transforms as a vector under  $SO(3)$ .

The other irreducible representations of  $SO(3)$  (i.e. those for integer spin) can also be obtained by adding various spin 1 together, which means taking the tensor products of several spin 1 representation, and decomposing them into irreducible representation. In particular, the spin  $s$  can be obtained by tensoring  $s$  spin 1 together, and keeping the symmetric traceless part in the irreducible decomposition of the tensor. Thus, the representation of spin  $s$  of the rotation group  $SO(3)$  acts on a totally symmetric and traceless tensor  $\psi_{i_1 i_2 \dots i_s}$ :

$$\psi_{i_1 \dots j \dots k \dots i_s} = \psi_{i_1 \dots k \dots j \dots i_s}, \quad \psi_{jj i_3 \dots i_s} = 0. \quad (328)$$

For example, for spin 2 one would consider

$$\mathbf{1} \otimes \mathbf{1} = \mathbf{0} \oplus \mathbf{1} \oplus \mathbf{2} \quad (329)$$



which contains the spin 2 representation **2**. This translates into considering the tensor product of the wave functions  $\psi_i$  and  $\chi_i$ , and decomposing it as

$$\psi_i \chi_j \equiv M_{ij} = S_{ij} + A_{ij} = \frac{1}{3} \delta_{ij} S + A_{ij} + \hat{S}_{ij} \quad (330)$$

where  $S_{ij} = \frac{1}{2}(M_{ij} + M_{ji})$  is the symmetric part,  $A_{ij} = \frac{1}{2}(M_{ij} - M_{ji})$  the antisymmetric part,  $S = \delta_{ij} S_{ij} = S_{ii}$  the trace (the scalar of spin 0), and  $\hat{S}_{ij} = S_{ij} - \frac{1}{3} \delta_{ij} S$  the traceless symmetric part (the spin 2). The representation identified by  $A_{ij}$  corresponds to spin 1, as evident by the change of basis  $V_i = \frac{1}{2} \epsilon_{ijk} M_{ij}$  ( $\epsilon_{ijk}$  is an invariant tensor for  $SO(3)$ ).

Thus spin  $s$  is described by a totally symmetric and traceless wave function  $\psi_{i_1 i_2 \dots i_s}(\vec{x})$ .

To have a relativistic description for a particle of spin  $s$ , that would be manifestly covariant, one would need to add time-like components to have tensors under the Lorentz group

$$\psi_i \rightarrow \psi_\mu \equiv A_\mu, \quad \psi_{i_1 i_2 \dots i_s} \rightarrow \psi_{\mu_1 \mu_2 \dots \mu_s} = \phi_{\mu_1 \mu_2 \dots \mu_s} \quad (331)$$

as used in the Fierz-Pauli description. However, the additional components should be eliminated somehow, as they were not there to start with. The Fierz-Pauli constraints do precisely that in a covariant manner.